

EXHIBIT B

Columbus Consolidated Government

Ammunition for Public Safety Departments (Annual Contract)

RFB No. 20-0062

Request for Bids

COLUMBUS CONSOLIDATED GOVERNMENT
Georgia's First Consolidated Government



FINANCE DEPARTMENT
PURCHASING DIVISION

100 TENTH STREET, P. O. Box 1340
COLUMBUS, GEORGIA 31902-1340
706-225-4087, Fax 706-225-3033
Bid Line 706-653-4536
www.columbusga.org

June 10, 2020

Addendum No. 1
Ammunition For Public Safety Departments
(Annual Contract)
RFB No. 20-0062

Submissions should include acknowledgement of receipt for all Addenda:

Authorized Initials: _____ Firm: _____

Vendors are informed that the above subject RFB is hereby modified, corrected, or supplemented as specified, described and set forth in this Addendum:

QUESTIONS / RESPONSES

Question: "Is Section III missing from new format? Section III Police.

Response: The Police Department wishes to receive bids on Section I: Ammunition and Section II: Less Lethal. There is no Section III.

Question: "Police Dept - Section 1, 5th Item 9mm 147gr Sub-Sonic Do they want JHP – USA9JHP2 or FMJ USA9mm1?"

Response: The specifications have been changed to add 9mm Winchester 147gr Sub-Sonic FMJ. See Section 1, Item 5., 9mm 147gr Sub-Sonic.

Question: "Marshal's Office - Section 1 9mm +40 S+W Do they want a "bonded" or "non-bonded? Section 2 9mm +40 S+W Do they want JHP or FMJ training?"

Response: The specifications have been changed to add "Bonded". See Section 1, Item 3., 9mm and Item 4., .40 Caliber Federal. The specifications have been changed to add JHP/Ball for practice ammunition. See Section 2, Item 1., 9mm and Item 2., .40 Caliber Federal,

Question: *"Muscokee County Prison - 223 / 5.56mm What grain weight bullet do they want? 65gr or 55gr? Also, do they want a FMJ?"*

Response: **The specifications have been changed to add 65gr bullet FMJ, and is now Item 2 in the Section.**

Question: *"Sheriff's Office - 12 GA Rifle Slug Do they want a Reduced Recoil or Standard Load?"*

Response: **The specifications have been changed to add Reduced Recoil, and is now Item 5 in the Section.**

**Pricing Pages have been amended for all of the above items.
You must use the attached revised pricing pages.**

Please use attached "REVISED" PRICING PAGE for each Public Safety Department. The "Pricing Page" for Police has been revised.

**Andrea J. McCorvey
Purchasing Division Manager**



“REVISED” PRICING PAGE
AMMUNITION FOR PUBLIC SAFETY DEPARTMENTS
(Annual Contract) RFB NO. 20-0062

POLICE DEPARTMENT

VENDOR COMPANY NAME:							
Section I: AMMUNITION							
<u>Item</u>	<u>Caliber or Gauge</u>	<u>Name Brand</u>	<u>Bullet Weight</u>	<u>Notes</u>	<u>Estimated Quantity</u>	<u>Unit Price (Per Round)</u>	<u>Total Price</u>
1.	12 Gauge	Federal	00 Buck Shot	Reduced Recoil, 9 Pellet	25,000 RDS	\$	\$
2.	223	Hornady	55gr	TAP	15,000 RDS	\$	\$
3.	5.56	NATO	55 gr Ball	Reloaded	75,000 RDS	\$	\$
4.	38SPL	Precision	148gr	Hollow Base Wadcutter	25,000 RDS	\$	\$
5.	9MM	Winchester	147gr	Sub-Sonic FMJ	20,000 RDS	\$	\$
6.	45ACP	Federal	230gr	Ball, Standard Velocity	10,000 RDS	\$	\$
7.	308	Hornady	168gr	Match	2,000 RDS	\$	\$
8.	9mm	Reload Federal	124gr	FMJ	20,000 RDS	\$	\$
9.	223	Federal	55 BT	Gold Match Boat Tail, Hollow Point	3,000 RDS	\$	\$
10.	9mm	Hornady	135gr	Luger +P Flexlock Critical Duty	10,000 RDS	\$	\$
Total Section I							\$

VENDOR COMPANY NAME:				
Section II: LESS LETHAL				
<u>Item</u>	<u>Description</u>	<u>Estimated Quantity</u>	<u>Unit Price</u>	<u>Total Price</u>
1.	CTS 37mm CS Liquid Barricade Smokeless	10 ea.	\$	\$
2.	CTS 37mm CS Powder Barricade Smokeless	10 ea.	\$	\$
3.	CTS 37mm OC Liquid Barricade Smokeless	10 ea.	\$	\$
4.	CTS Indoor OC Vapor Grenade	5 ea.	\$	\$
5.	CTS CS Baffled Canister Grenade, Pyro Low Flame Potential	5 ea.	\$	\$
6.	40mm Rotary – OC Muzzle Blast Rounds	200 ea.	\$	\$
7.	40mm Rotary – Long Range CS	100 ea.	\$	\$
8.	12 gauge Defense Technology Corp. Desc. Drag Stabilized Bean Bag	100 ea.	\$	\$
Total Section II				\$
GRAND TOTAL Police Department				\$
(Sections I and II)				

“REVISED” PRICING PAGE

AMMUNITION FOR PUBLIC SAFETY DEPARTMENTS (ANNUAL CONTRACT) RFB NO. 20-0062

MARSHAL’S OFFICE

VENDOR COMPANY NAME:							
Section I: AMMUNITION							
Item	Caliber or Gauge	Name Brand	Bullet Weight	Notes	Estimated Quantity	Unit Price (Per Round)	Total Price
1.	12 Gauge	Remington LE	00 Buck, 8 Pellets	Reduced Recoil, PR12BK8-00	1,500 RDS	\$	\$
2.	223	Remington	55gr	Remington Premier Accutip (PRA223RD)	4,000 RDS	\$	\$
3.	9mm	Federal Tactical	147gr	HST HP (P9HST2) New, Bonded	3,000 RDS	\$	\$
4.	.40 Caliber	Federal Tactical	165gr	Tactical HP (LE40T3), Bonded	1,000 RDS	\$	\$
Total Section I							\$

Section II: PRACTICE AMMUNITION							
1.	9mm	Federal	147gr	JHP 850 FPR + P Ball	4,500 RDS	\$	\$
2.	.40 Caliber	Federal	165gr	JHP/Ball	500 RDS	\$	\$
3.	.223 Caliber	Remington	55gr	Ball L223R3BPPE	8,000 RDS	\$	\$
Total Section II							\$

GRAND TOTAL Marshal’s Office (Sections I and II)							\$
---	--	--	--	--	--	--	----

“REVISED” PRICING PAGE

AMMUNITION FOR PUBLIC SAFETY DEPARTMENTS (ANNUAL CONTRACT) RFB NO. 20-0062

MUSCOGEE COUNTY PRISON (MCP)

VENDOR COMPANY NAME:							
PRACTICE AMMUNITION							
<u>Item</u>	<u>Caliber or Gauge</u>	<u>Name Brand</u>	<u>Bullet Weight</u>	<u>Notes</u>	<u>Estimated Quantity</u>	<u>Unit Price (Per Round)</u>	<u>Total Price</u>
1.	9 mill Automatic	Remington	115gr	FMJ	67,000 RDS	\$	\$
2.	223 / 556 Rifle	Remington	65gr	FMJ	2,000 RDS	\$	\$
3.	12 Gauge	Remington	00 Buckshot	Reduced Recoil, 8 Pellet	2,000 RDS	\$	\$
GRAND TOTAL (MCP)							\$

“REVISED” PRICING PAGE

AMMUNITION FOR PUBLIC SAFETY DEPARTMENTS (ANNUAL CONTRACT) RFB NO. 20-0062

SHERIFF’S OFFICE

VENDOR COMPANY NAME:							
Section I: AMMUNITION							
<u>Item</u>	<u>Caliber or Gauge</u>	<u>Name Brand</u>	<u>Bullet Weight</u>	<u>Notes</u>	<u>Estimated Quantity</u>	<u>Unit Price (Per Round)</u>	<u>Total Price</u>
1.	.45 ACP	Hornady	220gr +P	FlexLock Critical Duty	13,000 RDS	\$	\$
2.	9mm	Hornady	135gr	Critical Duty	13,000 RDS	\$	\$
3.	.223 Cal	Hornady	55gr	TAP - Rifle	4,000 RDS	\$	\$
4.	12 Gauge	Remington	8 Pellet	00 Buckshot Reduced Recoil	1,000 RDS	\$	\$
5.	12 Gauge	Remington	1 OZ	Rifle Slug Reduced Recoil	1,000 RDS	\$	\$
6.	.45 ACP	Reload	230gr	FMJ or Jacketed Hollow Point	100,000 RDS	\$	\$
7.	9mm	Reload	115gr	FMJ or Jacketed Hollow Point	100,000 RDS	\$	\$
8.	223 Cal	New	55gr	FMJ or Jacketed Hollow Point	32,000 RDS	\$	\$
Total Section I							\$

“REVISED” PRICING PAGE

AMMUNITION FOR PUBLIC SAFETY DEPARTMENTS (ANNUAL CONTRACT) RFB NO. 20-0062

SHERIFF’S OFFICE

VENDOR COMPANY NAME:

Section II: MUNITIONS

<u>Item</u>	<u>Description</u>	<u>Estimated Quantity</u>	<u>Unit Price</u>	<u>Total Price</u>
<i>“All munitions that have a fuse with a pull ring must be equipped with a pull ring safety clip.”</i>				
1.	40mm Safe Smoke; 75 – 150 yards	50 ea.	\$	\$
2.	40mm Speed – Heat CS; 75 – 150 yards	70 ea.	\$	\$
3.	12 GA Diversionary Aerial Round	100 ea.	\$	\$
4.	12 GA Rubber Pellet Round	500 ea.	\$	\$
5.	12 GA Super Sock Bean Bag Round	150 ea.	\$	\$
6.	40mm Multiple Foam Baton, Smokeless 75-150 YD	20 ea.	\$	\$
Total Section II				\$

Section III: HAND DEPLOYABLE MUNITIONS

<i>“All munitions that have a fuse with a pull ring must be equipped with a pull ring safety clip.”</i>				
1.	Rubber Ball, w/ White Smoke	100 ea.	\$	\$
2.	Expulsion Grenade, Flameless	25 ea.	\$	\$
3.	Canister, Smoke	80 ea.	\$	\$
4.	Canister, Smoke, HC	50 ea.	\$	\$
5.	Canister, Smoke, Pocket	130 ea.	\$	\$
6.	Canister, CN	30 ea.	\$	\$
7.	Canister, OC	80 ea.	\$	\$
8.	Tactical Grenade, “Flash Bang”	25 ea.	\$	\$
9.	Tactical Grenade, “Flash Bang”, Small	25 ea.	\$	\$
10.	Tactical Grenade, “Flash Bang”, Training	25 ea.	\$	\$
11.	Tactical Grenade, “Flash Bang”, Training, Small	25 ea.	\$	\$
12.	CS Grenades Handheld	30 ea.	\$	\$
13.	Stinger Rubber Ball Grenades	20 ea.	\$	\$
14.	Stinger Rubber Ball Grenades w/ OC	20 ea.	\$	\$
Total Section III				\$
GRAND TOTAL Sheriff’s Office (Sections I, II and III)				\$

COLUMBUS CONSOLIDATED GOVERNMENT

Georgia's First Consolidated Government

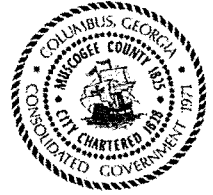

FINANCE DEPARTMENT PURCHASING DIVISION

100 TENTH STREET, COLUMBUS, GEORGIA 31901
P.O. Box 1340, COLUMBUS, GEORGIA 31902-1340
706-225-4087, Fax 706-225-3033
www.columbusga.org

Date: May 20, 2020

REQUEST FOR BIDS	Qualified vendors are invited to submit sealed bids, subject to conditions and instructions as specified for the furnishing of:
RFB No: 20-0062	AMMUNITION FOR PUBLIC SAFETY DEPARTMENTS (ANNUAL CONTRACT)
GENERAL SCOPE	Provide ammunition and munitions of various types and quantities on an "as needed" basis to Columbus Consolidated Government (the City) to be utilized by the Public Safety Departments. The contract term will be for two (2) years with option to renew for three (3) additional twelve-month periods.
DUE DATE	June 17, 2020 - 2:30 PM (Eastern)
BID SUBMISSION REQUIREMENTS	Due to the COVID-19 pandemic, the Purchasing Division is suspending the receipt of hard copies of sealed responses and public solicitation openings until further notice. Effective Immediately, responses must be submitted via DemandStar. See Appendix A for Submission Requirements, Submission Requirements Checklist, and DemandStar Registration and Submission Instructions.
ADDENDA	<u>IMPORTANT INFORMATION</u> Any and all addenda will be posted on the Purchasing Division's web page, at https://www.columbusga.gov/finance/purchasing/docs/opportunities/Bid_Opportunities.htm . It is the vendors' responsibility to periodically visit the web page for addenda before the due date and prior to submitting a quote.
"NO BID" RESPONSE	Refer to the form on page 3 if you are not interested in this invitation.

Andrea J. McCorvey
Purchasing Division Manager



IMPORTANT INFORMATION

e-Notification

The City uses the Georgia Procurement Registry e-notification system. You must register with the Team Georgia Market Place/Georgia Procurement Registry to receive future procurement notifications via [http://doas.ga.gov/state-](http://doas.ga.gov/state-purchasing/suppliers/getting-started-as-a-supplier)

[purchasing/suppliers/getting-started-as-a-supplier](http://doas.ga.gov/state-purchasing/suppliers/getting-started-as-a-supplier).

If you have any questions or encounter any problems while registering, please contact the Team Georgia Marketplace Procurement Helpdesk:

Telephone: 404-657-6000

Fax: 404-657-8444

Email: procurementhelp@doas.ga.gov

STATEMENT OF "NO BID"

Notify the Purchasing Division if you do not intend to submit a bid:

Email: BidOpportunities@ColumbusGA.org
Fax: 706-225-3033
Attn: Patti Postorino
Buyer

We, the undersigned decline to bid on your RFB NO. 20-0062 for AMMUNITION FOR PUBLIC SAFETY DEPARTMENTS (ANNUAL CONTRACT) for the following reason(s):

- Specifications too "tight", i.e. geared toward one brand or manufacturer only (explain below)
- There is insufficient time to respond to the Invitation for Bids.
- We do not offer this product or service.
- We are unable to meet specifications.
- We are unable to meet bond requirements.
- Specifications are unclear (explain below).
- We are unable to meet insurance requirements.
- Other (specify below)

Comments: _____

COMPANY NAME: _____

AGENT: _____

DATE: _____

EMAIL: _____

GENERAL PROVISIONS

THESE GENERAL PROVISIONS SHALL BE DEEMED AS PART OF THE BID SPECIFICATIONS.

The provisions of the Procurement Ordinance for the Consolidated Government of Columbus, Georgia as adopted and amended by Council shall apply to all invitations for bids and award of all contracts and is specifically incorporated herein by this reference. A copy of the ordinance is on file in the Purchasing Division.

1. **TERM "CITY"**. The term "City" as used throughout these documents will mean Consolidated Government of Columbus, Georgia.

2. **PREPARATION OF FORM**. Bid proposals shall be submitted on the forms provided by the City. All figures must be written in ink or typewritten. Figures written in pencil or erasures are not acceptable. However, mistakes may be crossed out, corrections inserted adjacent thereto, initialed in ink by the person signing the proposal. If there are discrepancies between unit prices quoted and extensions, the unit price will prevail. Failure to properly sign forms, in ink, will render bid incomplete.

3. **EXECUTION OF THE BID PROPOSAL**. Execution of the bid proposal will indicate the bidder is familiar and in compliance with all local laws, regulations, ordinances, site inspections, licenses, dray tags, etc.

4. **BID SUBMISSION. Bids must be submitted in a sealed envelope or package**. The exterior of the envelope or package must reference the bidder's name and address, the bid number, bid title, and must indicate the contents represent a "bid" or "no bid" submission. Failure to properly identify the bid submission may result in rejection of the bid.

5. **BID DUE DATE**. The bid submission must arrive in the Purchasing Division on or before the stated due date and time. Upon receipt, bids will be time and date stamped. Bids will remain sealed and secured until the stated due date and time for the bid opening.

6. **BID OPENING**. The Purchasing Division Manager or Purchasing staff appointee will open bids. The bid amount and other pertinent information as determined by the Purchasing Division Manager will be read and recorded. The bids as recorded at the bid opening represent a draft tabulation and may include incorrect price extensions or transcription errors, and are subject to change if conflicting information is discovered during analysis of the bid responses. A bid tabulation will be made available to bidders after extensions have been checked and all other specification compliance has been determined. **In the essence of time, bidders may not be allowed to review bids at the bid opening. However, bidders will be allowed to make appointments to review the bids at a later date.**

7. **LATE BIDS**. It is the responsibility of the bidder to ensure bids are submitted by the specified due date and time. Bids received after the stated date and time will be returned, unopened, to the bidder. The official clock to determine the date and time will be the time/date stamp located in the Finance Department. All bids received will be time and date stamped by the official clock. The City will not be held responsible for the late delivery of bids due to the U.S. Mail Service, or any other courier service.

8. **RECEIPT OF ONE SEALED BID**. In the event only one sealed bid is received, no formal bid opening shall take place. First, the Purchasing Division shall conduct a survey of vendors to inquire of "no bid" responses and non-responsive vendors. If, from the survey, it is determined by the Purchasing Division that specifications need revision, the one bid received will be returned, unopened, to the responding vendor, with a letter of explanation and a new bid solicitation prepared. If it is determined that other vendors need to be contacted, the bid due date will be extended, and the one bid received will remain sealed until the new bid opening date. The vendor submitting the single bid will receive a letter of explanation. **If it is determined the one bid received is from the only responsive, responsible bidder, then the bid shall be opened by the Purchasing Division Manager or designee, in the presence of at least one other witness. The single bid will be evaluated by the using agency for award recommendation.**

9. **RECEIPT OF TIE BIDS**. In the event multiple responsive, responsible bidders are tied for the lowest price and all other terms and requirements are met by the all tied bidders, the award recommendation shall be as follows:

- a. Award to the local bidder, if one of the bidders has its principal place of business in Columbus, Georgia.
- b. If all or none of the bidders has its principal place of business in Columbus, Georgia, then award the bid to the bidder who has received the award previously.
- c. If neither bidder received the award previously, and neither of the tied bidders has its principal place of business in Columbus, Georgia, then the bid award shall be equally divided between the tied bidders.
- d. If it is not feasible to divide the award, and if all or none of the tied bidders has its principal place of business in Columbus, Georgia, and neither was awarded the bid previously, then all bids will be rejected and the bid will be re-advertised.

10. **RECEIPT OF MULTIPLE BIDS**. **Unless otherwise stated in the bid specifications, the City will accept one and only one bid per vendor.** Any unsolicited multiple bid(s) will not be considered. If prior to the bid opening, more than one bid is received from the same vendor, the following will occur: (1) the bidder will be contacted and required to submit written

acknowledgment of the bid to be considered; (2) the additional bid(s) will be returned to the bidder unopened. If at the bid opening more than one bid is enclosed in a single bid package, the City will consider the vendor non-responsive and bids will be returned to the bidder.

11. CONDITIONS AND PACKAGING. Unless otherwise defined in the bid specifications, it is understood and agreed that any item offered or furnished shall be new, in current production and in first class condition, that all containers shall be new and suitable for storage or shipment, and that prices include standard commercial packaging.

12. FREIGHT/SHIPPING/HANDLING CHARGES. All freight, shipping, and handling charges shall be included in the bid price. The City will pay no additional charges.

13. CORRECTIONS OR WITHDRAWAL OF BID/CANCELLATION OF AWARDS. Corrections or withdrawals of inadvertently erroneous bids before or after bid opening, or cancellation of awards of contracts based on such bid mistakes may be permitted where appropriate. Mistakes discovered before bid opening may be modified or bid withdrawn by written notice received in the office of Purchasing prior to the time of the bid opening.

After bid opening, no changes in bid prices or other provisions of bids prejudicial to the interest of the City or fair competition shall be permitted. In lieu of bid correction, a low bidder alleging a material mistake of fact may be permitted to withdraw its bid if the mistake is clearly evident, or if the bidder submits evidence, which clearly and convincingly demonstrates that a mistake was made. All decisions to permit corrections or withdrawals of bids or to cancel awards or contracts based on bid mistakes will be supported by the written determination of the Purchasing Officer.

14. ADDENDA AND INTERPRETATIONS. If it becomes necessary to revise any part of this bid, a written addendum will be provided to all bidders. The City is not bound by any oral representations, clarifications, or changes made to the written specifications by City employees, unless such clarification or change is provided to the bidders in written addendum form from the Purchasing Officer. Bidders will be required to acknowledge receipt of the addenda (if applicable) in their sealed bid proposal. The vendor may provide an initialed copy of each addendum or initial the appropriate area on the bid form (pricing page). Failure to acknowledge receipt of the addenda (when applicable) will render bid incomplete. **It is the bidder's responsibility to ensure that they have received all addenda.**

15. BID EVALUATION AND AWARD. During the evaluation of bids, the City reserves the right to request clarification of bid responses and to request the submission of references, if deemed necessary for a complete evaluation of bid responses. Award will be made to the responsive and responsible bidder whose bid is most economical according to criteria designated in the solicitation. The determination of the lowest responsive and responsible bidder may involve all or some of the following factors: prices, conformity to specifications, financial ability to meet the contract, previous performance, facilities and equipment, availability of repair parts, experience, delivery promise, terms of payment, compatibility as required, other cost, and other objective and accountable factors, if any, (which are further described in the specifications). The City shall be the judge of the factors and will make the award in the best interest of the City.

16. TIME FOR CONSIDERATION. Bids must remain in effect for at least sixty (60) days after date of receipt to allow for evaluation.

17. BID SECURITY AND PERFORMANCE BOND. Bid security (Bid Bond) shall be required for all competitive sealed bids for construction contracts when the price is estimated by the Purchasing Officer to exceed \$10,000. Bid security shall be a bond provided by a surety company authorized to do business in the State, or in the form of a certified check. Such bonds may also be required on construction contracts under \$10,000 or other procurement contracts when circumstances warrant. Bid security shall be in an amount equal to at least five percent (5%) of the bid amount. The City will accept a copy of a bid bond at the bid opening. However, if a copy of a bid bond is submitted, the bidder must submit to the Purchasing Division the identical original document within five (5) days after the bid opening. **If the original document is not received within the five (5) days, the bid will not be considered.**

When a construction contract is awarded in excess of \$25,000 the successful bidder will be required to furnish a **Performance Bond** executed by a surety company authorized to do business in the State. The performance bond shall be equal to one hundred percent (100%) of the price specified in the bid.

18. SUBCONTRACTING. Should bidder intend to subcontract all or any part of the work specified, name(s) and address(es) of sub-contractor(s) must be provided in bid proposal (use additional sheet if necessary). The bidder shall be responsible for subcontractor(s) full compliance with the requirements of the bid specifications. **THE COLUMBUS CONSOLIDATED GOVERNMENT WILL NOT BE RESPONSIBLE FOR PAYMENTS TO SUBCONTRACTORS.**

19. DISQUALIFICATION OF BIDDERS AND REJECTION OF BIDS. Bidders may be disqualified and rejection of bid proposals may be recommended by the City for any (but not limited) to the following reasons:

- (A) Receipt after the time limit for receiving bid proposals as stated in the bid invitation.
- (B) Any irregularities contrary to the General Provisions or bid specifications.
- (C) Unbalanced unit price or extensions.
- (D) Unbalanced value of items.

- (E) Failure to use the proper forms furnished by the Consolidated Government.
- (F) Failure to complete the proposal properly
- (G) Omission of warranty, product literature, samples, acknowledgment of addenda or other items required to be included with bid proposal.
- (H) Failure to properly sign forms in ink.

The City reserves the right to waive any minor informality or irregularity. The City reserves the right to reject any and all bids.

20. BRAND NAMES "OR EQUAL". Whenever in this invitation any particular material, process and/or equipment are indicated or specified by patent, proprietary or brand name of manufacturer, such wording will be deemed to be used for the purpose of facilitating description of the material, process and/or equipment desired by the City. It is not meant to eliminate bidders or restrict competition in any bid process. Any manufacturers' names, drawings, trade names, brand names, specifications and/or catalog numbers used herein are for the purpose of description and establishing general quality levels. Bidders may propose equivalent equipment, services or manufacturer. Any proposal that is equivalent to or surpasses stated specifications will be considered. Determination of equivalency shall rest solely with the City. **Please Note: Due to existing equipment, specific manufacturers may be required to facilitate compatibility.**

21. ASSIGNMENT OF CONTRACTUAL RIGHTS. It is agreed that the successful bidder will not assign, transfer, convey or otherwise dispose of the contract or its right, title or interest in or to the same, or any part thereof, without previous consent of the City and any sureties.

22. DISCOUNTS. Terms of payments offered will be reflected in the space provided on the bid proposal form. Cash discounts will be considered net in the bid evaluation process. All terms of payment (cash discounts) will be taken and computed from the date of delivery of acceptable material or services, or the date of receipt of the invoice, whichever is later.

23. TAXES. The City is exempt from State Retail Tax and Federal Excise Tax. Tax Exemption No. GA Code Sec. 48-8-3. Federal ID No. 58-1097948.

24. FEDERAL, STATE AND LOCAL LAWS. All bidders will comply with all Federal, State, and Local laws and ordinances, relative to conducting business in Columbus, Georgia.

25. BID INCLUSIONS. When bid inclusions are required, such as warranty information, product literature/specifications, references, etc. The inclusions should reference all aspects of the specific equipment or service proposed by the bidder. Do not include general descriptive catalogs. References to literature or other required inclusions submitted previously does not satisfy this provision. Bids found to be in non-compliance with these requirements will be subject to rejection.

26. NON-COLLUSION. By signing and submitting this bid, bidder declares that its agents, officers or employees have not directly or indirectly entered into any agreements, participated in any collusion or otherwise taken any action in restraint of free competitive bidding in connection with this bid. In the event, said bidder is found guilty of collusion, the company and agents will be removed from the City's bid list for one full year and any current orders will be canceled.

27. INDEMNITY. The successful bidder agrees, by entering into this contract, to defend, indemnify and hold City harmless from any and all causes of action or claims of damages arising out or under this contract.

28. DISADVANTAGED BUSINESS ENTERPRISE. Disadvantaged Business Enterprises (minority or women owned businesses) will be afforded full opportunity to submit proposals in response to this invitation and will not be discriminated against on the grounds of race, color, creed, sex, sexual orientation, gender identity or national origin in consideration for an award. It is the policy of the City that disadvantaged business enterprises and minority business enterprises have an opportunity to participate at all levels of contracting in the performance of City contracts to the extent practical and consistent with the efficient performance of the contract.

29. AFFIRMATIVE ACTION PROGRAM - NON-DISCRIMINATION CLAUSE. The City has an Affirmative Action Program in connection with Equal Employment Opportunities. The successful bidder will comply with all Federal and State requirements concerning fair employment and employment of the handicapped, and concerning the treatment of all employees, and will not discriminate between or among them by reason of race, color, age, religion, sex, sexual orientation, gender identity, national origin or physical handicap.

30. AWARDS TO LOCAL BUSINESSES. Except for construction contracts, awards will be made to responsive and responsible local businesses proposing a cost not more than two percent (2%) above the low bid or quote for contracts involving an expenditure of \$25,000.00 or less and made to responsive and responsible local businesses proposing a cost not more than one percent (1%) above the low bid or quote for contracts involving an expenditure greater than \$25,000.00. (Ordinance No. 09-0024, Section 3-117). ****STATE OR FEDERALLY FUNDED PROJECTS EXCLUDED****

31. RIGHT TO PROTEST. A protest with respect to an Invitation for bids or Request for Proposals shall be submitted in writing no less than five (5) days prior to the opening of bids or the closing date of proposals to the Purchasing Officer. If the matter is not resolved, then an appeal may be filed with the City Manager or City Council.

32. FAILURE TO QUOTE. Vendors choosing not to submit a bid are requested to return a **Statement of "No Bid"**.

33. PRODUCT/EQUIPMENT DEMONSTRATION - SITE VISIT. During the evaluation of bids, the City reserves the right to request a demonstration or site visit of the product, equipment or service offered by a bidder. The demonstration or site visit shall be at the expense of the bidder. Bidders who fail to provide demonstration or site visit, as requested, will be considered non-responsive.

34. CANCELLATION PROVISIONS. When such action is in the best financial interest of the City, contracts for supplies to be purchased or services to be rendered under an annual (term) contract basis may be canceled and re-advertised at the discretion of the Purchasing Officer and in accordance with contract terms.

After the receipt of a product or piece of equipment, it is found that said item does not perform as specified and required, payment for said product or equipment will be withheld. The successful vendor will be notified of the non-performance in writing. After notification, the successful vendor will have ten (10) calendar days, from the date of notification, to deliver product or equipment which performs satisfactorily. If a satisfactory product is not delivered within 10 calendar days, from the notification date, the City will cancel the contract (purchase order) and award to the next low, responsive, responsible bidder. The vendor will be responsible for the pick-up or shipment of the unsatisfactory equipment or product.

35. QUESTIONS: Questions concerning specifications must be submitted, in writing, at least 5 (five) working days (Monday-Friday) prior to receipt date. Questions received less than five working days prior to receipt date will not be considered.

36. SAMPLES: When samples are required to be included with the proposal response, the bidder will be responsible for the following:

- 1) **Unless otherwise specified**, bidders are required to submit exact samples of item(s) bid. Do not submit sample of "like" item(s).
- 2) Affix an identification label to each individual sample to include bidder's name, bid name and number.
- 3) Make arrangements for the return of sample after the bid award. All shipping costs will be the responsibility of the bidder. If bidder does not make arrangements for return of sample, within 60 days after award, the sample will be discarded.

37. GOVERNING LAW: The parties agree that this Agreement shall be governed by the laws of Georgia, both as to interpretations and performance.

38. PAYMENT DEDUCTIONS: The City reserves the right to deduct, from payments to awarded vendor(s), any amount owed to the City for various fees, to include, but not limited to: False Alarm fees, Ambulance fees, Occupation License Fees, Landfill fees, etc.

39. PAYMENT TERMS: The City's standard payment term is usually net 30 days, after successful receipt of goods or services. Payment may take longer if invoice is not properly documented or not easily identifiable, goods/services are not acceptable, or invoice is in dispute.

40. FINAL CONTRACT DOCUMENTS: If a formal contract is required as a result of the Request for Bid; the final contract shall include the following: 1) The RFB; 2) Addenda; 3) Awarded Vendor(s) Bid response; 4) Awarded Vendor(s) Clarifications; and 6) Awarded Vendor(s) Business Requirements.

NOTICE TO VENDORS

Columbus Council, by Ordinance 92-60 has prohibited any business which is owned by any member of Columbus Council or the Mayor, or any business in which any member of Columbus Council or the Mayor has a substantial pecuniary interest from submitting a bid for goods or services to the Consolidated Government of Columbus, Georgia.

Likewise, by Ordinance 92-61, no business which is owned by any member of any board, authority or commission, subordinate or independent entity, or any business in which any member of any board, authority or commission, subordinate or independent entity has substantial pecuniary interest may submit a bid to the Consolidated Government if such bid pertains to the board, authority or commission.

DO YOU HAVE QUESTIONS, CONCERNS OR NEED CLARIFICATION ABOUT THIS SOLICITATION?

COMMUNICATION CONCERNING ANY SOLICITATION CURRENTLY ADVERTISED MUST TAKE PLACE IN WRITTEN FORM AND ADDRESSED TO THE PURCHASING DIVISION.

ALL QUESTIONS OR CLARIFICATIONS CONCERNING THIS SOLICITATION SHALL BE SUBMITTED IN WRITING. THE CITY WILL NOT ORALLY OR TELEPHONICALLY ADDRESS ANY QUESTION OR CLARIFICATION REGARDING BID/PROPOSAL SPECIFICATIONS. IF A VENDOR VISITS OR CALLS THE PURCHASING DIVISION WITH SUCH QUESTIONS, HE OR SHE WILL BE INSTRUCTED TO SUBMIT THE QUESTIONS IN WRITING.

ALL CONTACT CONCERNING THIS SOLICITATION SHALL BE MADE THROUGH THE PURCHASING DIVISION. BIDDERS SHALL NOT CONTACT CITY EMPLOYEES, DEPARTMENT HEADS, USING AGENCIES, EVALUATION COMMITTEE MEMBERS OR ELECTED OFFICIALS WITH QUESTIONS OR ANY OTHER CONCERNS ABOUT THE SOLICITATION. QUESTIONS, CLARIFICATIONS, OR CONCERNS SHALL BE SUBMITTED TO THE PURCHASING DIVISION IN WRITING. IF IT IS NECESSARY THAT A TECHNICAL QUESTION NEEDS ADDRESSING, THE PURCHASING DIVISION WILL FORWARD SUCH TO THE USING AGENCY, WHO WILL SUBMIT A WRITTEN RESPONSE.

THE PURCHASING DIVISION WILL FORWARD WRITTEN RESPONSES TO THE RESPECTIVE BIDDER OR IF IT BECOMES NECESSARY TO REVISE ANY PART OF THIS SOLICITATION, A WRITTEN ADDENDUM WILL BE ISSUED TO ALL BIDDERS.

THE CITY IS NOT BOUND BY ANY ORAL REPRESENTATIONS, CLARIFICATIONS, OR CHANGES MADE TO THE WRITTEN SPECIFICATIONS BY CITY EMPLOYEES, UNLESS SUCH CLARIFICATION OR CHANGE IS PROVIDED TO THE BIDDERS IN A WRITTEN ADDENDUM FROM THE PURCHASING MANAGER.

BIDDERS ARE INSTRUCTED TO USE THE ENCLOSED "QUESTION/CLARIFICATION FORM" TO FAX OR EMAIL QUESTION.

ANY REQUEST, AFTER A SOLICITATION HAS CLOSED AND PENDING AWARD, MUST ALSO BE SUBMITTED IN WRITING TO THE PURCHASING DIVISION.

QUESTION/CLARIFICATION FORM

DATE: _____

TO: Patti Postorino, Buyer
 Email BidOpportunities@ColumbusGA.org or
 Fax 706-225-3033

RE: RFB No. 20-0062; Ammunition for Public Safety Departments (Annual Contract)

Questions/clarification requests must be submitted at least five (5) business days before the due date:

From: _____

Company Name	Website		
Representative	Email Address		
Complete Address	City	State	Zip
Telephone Number	Fax Number		

GENERAL SPECIFICATIONS

AMMUNITION FOR PUBLIC SAFETY DEPARTMENTS (ANNUAL CONTRACT) RFB No. 20-0062

I. SCOPE

The Consolidated Government of Columbus, Georgia (the City) is seeking vendors to provide ammunition and munitions of various types and quantities on an "as needed" basis to be utilized by the Public Safety Departments. ***The City reserves the right to add alike items during the term of the contract. Quotes will be obtained from contracted vendor(s) for any additional items.***

II. TERM OF CONTRACT

A. The term of contract shall be for two (2) years, with the option to renew for three (3) additional twelve-month periods. Contract renewal will be contingent upon the mutual agreement of the City and the Contractor.

Notice of intent to renew will be given to the contractor in writing by the Purchasing Division Director, normally sixty days before the expiration date of the current contract. This notice shall not be deemed to commit the City to a Contract renewal.

It should be noted that multi-year contracts may be continued each fiscal year only after funding appropriations and programs approval has been granted by the Council of the Consolidated Government of Columbus, Georgia. In the event the necessary funding is not approved, then the affected multi-year contract becomes null and void, effective July 1st of the fiscal year for which such approval has been denied.

B. Termination for Convenience

For the protection of both parties, either party giving 30 days prior notice in writing to the other party may cancel this contract.

III. ESCALATION CLAUSE

Contract pricing shall remain fixed for the initial two (2) year term of the contract. After the initial term, Contractor may request a price escalation by submitting a fully documented request (i.e. documentation from manufacturers illustrating the necessity to implement price increases).

Request for price increases, without documentation, shall not be considered. Such escalation shall not exceed a five percent (5%) increase. The using department(s) and the Purchasing Manager will review the request and shall approve or disapprove the increases based on budget constraints and other price comparisons.

If for any reason the contractor has a price increase that exceeds five percent (5%), the price increase will be evaluated on a case-by-case basis. The City and the Contractor will have the option to discuss and make adjustments to the requested increase. If either party declines approval of the adjustments, the contract will be considered cancelled on the scheduled expiration date of the contract.

VI. QUESTIONS / ADDENDA

Questions and requests for clarification must be submitted **within five (5) business days of the due date** (see pages 8 & 9). Changes to the specifications (if any) will be provided in the form of an addendum, which will be posted on the web page of the Finance Department/Purchasing Division of Columbus Consolidated Government at https://www.columbusga.org/finance/purchasing/docs/opportunities/Bid_Opportunities.htm.

It is the vendors' responsibility to periodically visit the web page for addenda before the due date and prior to submitting a quote.

V. **BRAND NAMES**

Reference to a particular trade name, brand name, manufacturer, catalog or model number are made for descriptive purposes to guide the bidder in interpreting the requirements of the City. They should not be construed as nor are they intended to exclude proposals on other materials and supplies. However, there are certain facilities owned by the City of Columbus that require a particular brand name product to be compatible with the existing equipment. Therefore, should the successful bidder not be able to supply the required product, the City of Columbus reserves the right to purchase from another vendor. Any proposal that is equivalent to or surpasses stated specifications would be considered. Determination of equivalency shall rest solely with the City. **NOTE: Specific manufacturers may be required to accommodate compatibility with existing equipment. Therefore, it is requested that bid responses be submitted in accordance with the specifications provided.**

VI. **INDEMNITY CLAUSE**

The Contractor covenants to save, defend, hold harmless, and indemnify the City, and all of its officers, departments, agencies, agents, and employees (collectively the "City") from and against any and all claims, losses, damages, injuries, fines, penalties, costs (including court costs and attorney's fees), charges, liability, or exposure, however caused, resulting from, arising out of, or in any way connected with the Contractor's intentional, negligent, or grossly negligent acts or omissions in performance or nonperformance of its work called for by the Contract Documents.

VII. **BID SUBMISSION REQUIREMENTS**

Each bidder shall include the following information with bid submission. Bidder shall submit **ONE (1) ELECTRONIC BID RESPONSE VIA DEMANDSTAR**. The City reserves the right to request any omitted information, **to exclude *Communication Concerning This Solicitation (Form 1)*, WHICH DOES NOT AFFECT THE SUBMITTED BID PRICE**. Bidders shall be notified, in writing, and shall have two (2) days, after notification to submit the omitted information. If the omitted information is not received within two (2) days, the Bidder shall be deemed non-responsive and the Bid Submission will be deemed **"Incomplete"**:

- A. **Communication Concerning This Solicitation:** (Form 1)
- B. **Bid Form and Pricing Pages** (Form 2 and Pages 16-20)
- C. **Contract Signature Page:** (Form 3) Provide all required information
- D. **Product Literature:** Bidder shall submit the latest printed specifications and advertising literature on the item(s) they propose to furnish.
- E. **Warranty / Shelf Life:** Provide written warranty and shelf life for ammunition.
- F. **Sample Invoice:** Provide an itemized Invoice sample depicting the billing format for the discount for non-listed items.
- G. **Addenda:** Vendors must include acknowledgment of receipt of addenda (if any) in their sealed bid. Provide an initialed copy of each addendum or initial the appropriate area on bid form (pricing page). Addenda will be posted at https://www.columbusga.gov/finance/purchasing/docs/opportunities/Bid_Opportunities.htm
Vendors are responsible for periodically visiting the web page, to check for addenda, prior to the bid due date and before submitting a bid.
- H. **Business License:** Vendors located in Muscogee County shall submit a current copy of their City of Columbus Business License (Occupation License). If the business is not located in Muscogee County and has proof of being properly licensed by a municipality in Georgia, and paid applicable occupation taxes in that city, the vendor will not be required to pay occupation taxes in Columbus, Georgia.
If the business location is not in Georgia, vendor must provide a current copy of their active Articles of Incorporation from the State and/or a current business license from the City/State in which business is located.

If you have questions regarding this requirement, please contact Yvonne Ivey, Revenue Manager: 706-225-3091.

I. W-9 Rev 2018 Request for Taxpayer Identification Number and Certification (Form 4)

IX. AWARD/ORDERING/DELIVERY/INVOICE

- A. Award: The City may award the contract to one vendor or make an award by sections to multiple vendors, whichever is in the best interest of the City. The City reserves the right to reject any and all bids. Should the successful bidder(s) not be able to supply the required items(s), the City reserves the right to purchase from other sources.
- B. Ordering: After award of the bid by Columbus City Council, the successful vendor(s) shall receive orders on an "as needed" basis, either by faxed or e-mailed purchase order. The City reserves the right to make **emergency purchases** from other sources, should the Contractor be unable to furnish the required item/service within the required time.
- C. Delivery: The successful bidder(s) shall state on the bid form the days for delivery from the time the order is placed. The days shall be stated in calendar days. Inability to make delivery within specified time will authorize the City to purchase from other sources. All shipping, delivery, and/or freight charges must be included in the Unit Price. Columbus Consolidated Government will pay no additional shipping, delivery, and/or freight charges or any other additional fees. Deliveries shall be made to the applicable address.
- D. Invoices: After receipt of goods/services and upon satisfactory delivery, the successful vendor shall forward itemized invoice(s) to the following address:

Columbus Consolidated Government
Accounting Division
P. O. Box 1340
Columbus, Georgia 31902-1340

The invoice(s) shall reference the bid number (RFB No. 20-0062) and/or purchase order number.

X. TERMINATION OF CONTRACT

Default: If the contractor refuses or fails to perform any of the provisions of this contract with such diligence as will ensure its completion within the time specified in this contract, or any extension thereof, otherwise fails to timely satisfy the contract provisions, or commits any other substantial breach of this contract, the Purchasing Division Director may notify the contractor in writing of the delay or non-performance and if not cured within ten (10) days or any longer time specified in writing by the Purchasing Division Director, such director may terminate the contractor's right to proceed with the contract or such part of the contract as to which there has been delay or a failure to properly perform.

In the event of termination in whole or in part the Purchasing Division Director may procure similar supplies or services, from other sources, in a manner and upon terms deemed appropriate by the Purchasing Division Director. The contractor shall continue performance of the contract to the extent it is not terminated and shall be liable for excess costs incurred in procuring similar goods or services.

Compensation: Payment for completed supplies delivered and accepted by the city shall be at the contract price. The City may withhold from amounts due the contractor such sums as the Purchasing Director deems to be necessary to protect the City against loss because of

outstanding liens or claims of former lien holders and to reimburse the City for the excess costs incurred in procuring similar goods and services.

Excuse for Nonperformance or Delayed Performance: Except with respect to defaults of subcontractors, the contractor shall not be in default by reason of any failure in performance of this contract in accordance with its terms, if the contractor has notified the Purchasing Division Director within 15 days after the cause of the delay and the failure arises out of causes such as: acts of God; acts of public enemy; acts of the City and any other governmental entity in its sovereign or contractual capacity; fires; floods; epidemics; quarantine restrictions; strikes or other labor disputes; freight embargoes; or unusually severe weather. If the failure to perform is caused by the failure of a subcontractor to perform or to make progress, and if such failure arises out of causes similar to those set forth above, the contractor shall not be deemed to be in default, unless the supplies or services to be furnished by the subcontractor were reasonably obtainable from other sources in sufficient time to permit the contractor to meet the contract requirements.

Upon request of the contractor, the Purchasing Division Director shall ascertain the facts and extent of such failure, and, if such director determines that any failure to perform was occasioned by any one or more of the excusable causes, and that, but for the excusable cause, the contractor's progress and performance would have met the terms of the contract, the delivery schedule shall be revised accordingly.

FORM 1

COMMUNICATION CONCERNING THIS SOLICITATION

THIS PAGE MUST BE SIGNED AND RETURNED WITH THE VENDOR'S BID/PROPOSAL. FAILURE TO INCLUDE THIS FORM WILL AUTOMATICALLY RENDER VENDOR'S RESPONSE NON-RESPONSIVE.



ALL QUESTIONS OR CLARIFICATIONS CONCERNING THIS SOLICITATION SHALL BE SUBMITTED IN WRITING. THE CITY WILL NOT ORALLY OR TELEPHONICALLY ADDRESS ANY QUESTION OR CLARIFICATION REGARDING BID/PROPOSAL SPECIFICATIONS. IF A VENDOR VISITS OR CALLS THE PURCHASING DIVISION WITH SUCH QUESTIONS, HE OR SHE WILL BE INSTRUCTED TO SUBMIT THE QUESTIONS IN WRITING.

ALL CONTACT CONCERNING THIS SOLICITATION SHALL BE MADE THROUGH THE PURCHASING DIVISION. BIDDERS SHALL NOT CONTACT CITY EMPLOYEES, DEPARTMENT HEADS, USING AGENCIES, EVALUATION COMMITTEE MEMBERS, INCLUDING NON-CCG EMPLOYEES, CONTRACTED PERSONNEL ASSOCIATED WITH THIS PARTICULAR PROJECT (I.E. ARCHITECTS, ENGINEERS, CONSULTANTS), OR ELECTED OFFICIALS WITH QUESTIONS OR ANY OTHER CONCERNS ABOUT THE SOLICITATION. QUESTIONS, CLARIFICATIONS, OR CONCERNS SHALL BE SUBMITTED TO THE PURCHASING DIVISION IN WRITING. IF IT IS NECESSARY THAT A TECHNICAL QUESTION NEEDS ADDRESSING, THE PURCHASING DIVISION WILL FORWARD SUCH TO THE USING AGENCY, WHO WILL SUBMIT A WRITTEN RESPONSE.

THE PURCHASING DIVISION WILL FORWARD WRITTEN RESPONSES TO THE RESPECTIVE BIDDER. IF IT BECOMES NECESSARY TO REVISE ANY PART OF THIS SOLICITATION, A WRITTEN ADDENDUM WILL BE ISSUED TO ALL BIDDERS.

THE CITY IS NOT BOUND BY ANY ORAL REPRESENTATIONS, CLARIFICATIONS, OR CHANGES MADE TO THE WRITTEN SPECIFICATIONS BY CITY EMPLOYEES, UNLESS SUCH CLARIFICATION OR CHANGE IS PROVIDED TO THE BIDDERS IN A WRITTEN ADDENDUM FROM THE PURCHASING MANAGER.

BIDDERS ARE INSTRUCTED TO USE THE ENCLOSED "QUESTION/CLARIFICATION FORM" TO FAX OR EMAIL QUESTION. **QUESTIONS AND REQUESTS FOR CLARIFICATION MUST BE SUBMITTED AT LEAST FIVE (5) BUSINESS DAYS BEFORE THE DUE DATE.**

ANY REQUEST/CONCERN/PROTEST, AFTER A SOLICITATION HAS CLOSED AND PENDING AWARD, MUST ALSO BE SUBMITTED IN WRITING TO THE PURCHASING DIVISION.

I agree to forward all communication about this solicitation, in writing, to the Purchasing Division. I understand that communication with other persons, other than the Purchasing Division, will render my Bid/Proposal response non-responsive and I will no longer be considered in the solicitation process.

Vendor Name: _____

Print Name of Authorized Agent: _____

Signature of Authorized Agent: _____

FORM 2

BID FORM

AMMUNITION FOR PUBLIC SAFETY DEPARTMENTS (ANNUAL CONTRACT) RFB No. 20-0062

IMPORTANT INFORMATION:

PLEASE SUBMIT ONE (1) ELECTRONIC BID RESPONSE VIA DEMANDSTAR.

By signing this Bid Form, the authorized representative understands the City reserves the right to request any omitted information, *with the exception of the "Communication Concerning This Solicitation" (Form 1), WHICH DOES NOT AFFECT THE SUBMITTED BID PRICE.* Bidders shall be notified, in writing, and shall have two (2) days, after notification to submit the omitted information. If the omitted information is not received within two (2) days, the Bidder shall be deemed non-responsive and the Bid Submission will be deemed "Incomplete". Use the following checklist to verify the items are included in sealed bid:

- Communication Concerning This Solicitation (Form 1) Bid Form (Form 2)
- Pricing Pages (pages 16-20) Contract Signature Page (Form 3) Production Literature
- Warranty & Shelf Life Info Sample Itemized Invoice Business License 2020 W-9 Rev 2018 (Form 4)

Initial below to acknowledge receipt of the following addenda (if any):

Addendum No. 1 _____ Addendum No. 2 _____ Addendum No. 3 _____

The undersigned hereby declares that he has/they have carefully examined the specifications herein referred to and will provide all services and terms of the Columbus Consolidated Government.

*All shipping, delivery, and/or freight charges must be included in unit price. Columbus Consolidated Government will pay no additional shipping, delivery and/or freight charges or any other additional fees. Inability to make delivery within specified time will authorize the City to purchase from other sources.

Delivery will be made _____ day(s) after receipt of purchase order.

Vendor Business Name

Email Address

Authorized Signature

Print Name of Signatory

Date

Please circle and initial if Business is {Minority} or {Woman} Owned: _____

If certified as a DBE or WBE, list the certifying agency: _____

Not Minority, Woman or DBE owned (please initial) _____

PRICING PAGE

AMMUNITION FOR PUBLIC SAFETY DEPARTMENTS (ANNUAL CONTRACT) RFB NO. 20-0062

POLICE DEPARTMENT

VENDOR COMPANY NAME:						
Section I: AMMUNITION						
<u>Estimated Quantity</u>	<u>Caliber or Gauge</u>	<u>Name Brand</u>	<u>Bullet Weight</u>	<u>Notes</u>	<u>Unit Price (Per Round)</u>	<u>Total Price</u>
25,000 RDS	12 Gauge	Federal	00 Buck Shot	Reduced Recoil, 9 Pellet	\$	\$
15,000 RDS	223	Hornady	55gr	TAP	\$	\$
75,000 RDS	5.56	NATO	55 gr Ball	Reloaded	\$	\$
25,000 RDS	38SPL	Precision	148gr	Hollow Base Wadcutter	\$	\$
20,000 RDS	9MM	Winchester	147gr	Sub-Sonic	\$	\$
10,000 RDS	45ACP	Federal	230gr	Ball, Standard Velocity	\$	\$
2,000 RDS	308	Hornady	168gr	Match	\$	\$
20,000 RDS	9mm	Reload Federal	124gr	FMJ	\$	\$
3,000 RDS	223	Federal	55 BT	Gold Match Boat Tail, Hollow Point	\$	\$
10,000 RDS	9mm	Hornady	135gr	Luger +P Flexlock Critical Duty	\$	\$
Total Section I						\$

VENDOR COMPANY NAME:			
Section II: LESS LETHAL			
<u>Estimated Quantity</u>	<u>Description</u>	<u>Unit Price</u>	<u>Total Price</u>
10 ea.	CTS 37mm CS Liquid Barricade Smokeless	\$	\$
10 ea.	CTS 37mm CS Powder Barricade Smokeless	\$	\$
10 ea.	CTS 37mm OC Liquid Barricade Smokeless	\$	\$
5 ea.	CTS Indoor OC Vapor Grenade	\$	\$
5 ea.	CTS CS Baffled Canister Grenade, Pyro Low Flame Potential	\$	\$
200 ea.	40mm Rotary – OC Muzzle Blast Rounds	\$	\$
100 ea.	40mm Rotary – Long Range CS	\$	\$
100 ea.	12 gauge Defense Technology Corp. Desc. Drag Stabilized Bean Bag	\$	\$
Total Section III			\$
GRAND TOTAL Police Department (Sections I and II)			\$

PRICING PAGE

**AMMUNITION FOR PUBLIC SAFETY DEPARTMENTS
(ANNUAL CONTRACT) RFB NO. 20-0062**

MARSHAL'S OFFICE

VENDOR COMPANY NAME:						
Section I: AMMUNITION						
<u>Estimated Quantity</u>	<u>Caliber or Gauge</u>	<u>Name Brand</u>	<u>Bullet Weight</u>	<u>Notes</u>	<u>Unit Price (Per Round)</u>	<u>Total Price</u>
1,500 RDS	12 Gauge	Remington LE	00 Buck, 8 Pellets	Reduced Recoil, PR12BK8-00	\$	\$
4,000 RDS	223	Remington	55gr	Remington Premier Accutip (PRA223RC)	\$	\$
3,000 RDS	9mm	Federal Tactical	147gr	HST HP (P9HST2) New	\$	\$
1,000 RDS	.40 Caliber	Federal Tactical	165gr	Tactical HP (LE40T3)	\$	\$
Total Section I						\$
Section II: PRACTICE AMMUNITION						
4,500 RDS	9mm		147gr	JHP 850 FPS +P	\$	\$
500 RDS	.40 Caliber		165gr	JHP	\$	\$
8,000 RDS	.223 Caliber	Remington	55gr	Ball L223R3BPPE	\$	\$
Total Section II						\$
GRAND TOTAL Marshal's Office (Sections I and II)						\$

PRICING PAGE

**AMMUNITION FOR PUBLIC SAFETY DEPARTMENTS
(ANNUAL CONTRACT) RFB NO. 20-0062**

MUSCOGEE COUNTY PRISON (MCP)

VENDOR COMPANY NAME:						
PRACTICE AMMUNITION						
<u>Estimated Quantity</u>	<u>Caliber or Gauge</u>	<u>Name Brand</u>	<u>Bullet Weight</u>	<u>Notes</u>	<u>Unit Price (Per Round)</u>	<u>Total Price</u>
67,000 RDS	9 mill Automatic		115gr	FMJ	\$	\$
2,000 RDS	223 / 556 Rifle		65gr		\$	\$
2,000 RDS	12 Gauge	Remington	00 Buckshot	Reduced Recoil, 8 Pellet	\$	\$
GRAND TOTAL (MCP)						\$

PRICING PAGE

AMMUNITION FOR PUBLIC SAFETY DEPARTMENTS (ANNUAL CONTRACT) RFB NO. 20-0062

SHERIFF'S OFFICE

VENDOR COMPANY NAME:						
Section I: AMMUNITION						
<u>Estimated Quantity</u>	<u>Caliber or Gauge</u>	<u>Name Brand</u>	<u>Bullet Weight</u>	<u>Notes</u>	<u>Unit Price (Per Round)</u>	<u>Total Price</u>
13,000 RDS	.45 ACP	Hornady	220gr +P	FlexLock Critical Duty	\$	\$
13,000 RDS	9mm	Hornady	135gr	Critical Duty	\$	\$
4,000 RDS	.223 Cal	Hornady	55gr	TAP - Rifle	\$	\$
1,000 RDS	12 Gauge	Remington		00 Buckshot – 8 Pellet Reduced Recoil	\$	\$
1,000 RDS	12 Gauge	Remington	1 OZ	Rifle Slug	\$	\$
100,000 RDS	.45 ACP	Reload	230gr	FMJ or Jacketed Hollow Point	\$	\$
100,000 RDS	9mm	Reload	115gr	FMJ or Jacketed Hollow Point		
32,000 RDS	223 Cal	New	55gr	FMJ or Jacketed Hollow Point	\$	\$
Total Section I						\$

PRICING PAGE

**AMMUNITION FOR PUBLIC SAFETY DEPARTMENTS
(ANNUAL CONTRACT) RFB NO. 20-0062**

SHERIFF'S OFFICE

VENDOR COMPANY NAME:			
Section II: MUNITIONS			
<u>Estimated Quantity</u>	<u>Description</u>	<u>Unit Price</u>	<u>Total Price</u>
<i>"All munitions that have a fuse with a pull ring must be equipped with a pull ring safety clip."</i>			
50 EA.	40mm Safe Smoke; 75 – 150 yards	\$	\$
70 EA.	40mm Speed – Heat CS; 75 – 150 yards	\$	\$
100 EA.	12 GA Diversionary Aerial Round	\$	\$
500 EA.	12 GA Rubber Pellet Round	\$	\$
150 EA.	12 GA Super Sock Bean Bag Round	\$	\$
20 EA.	40mm Multiple Foam Baton, Smokeless 75-150 YD	\$	\$
Total Section II			\$
Section III: HAND DEPLOYABLE MUNITIONS			
<i>"All munitions that have a fuse with a pull ring must be equipped with a pull ring safety clip."</i>			
100 EA.	Rubber Ball, w/ White Smoke	\$	\$
25 EA.	Expulsion Grenade, Flameless	\$	\$
80 EA.	Canister, Smoke	\$	\$
50 EA.	Canister, Smoke, HC	\$	\$
130 EA.	Canister, Smoke, Pocket	\$	\$
30 EA.	Canister, CN	\$	\$
80 EA.	Canister, OC	\$	\$
25 EA.	Tactical Grenade, "Flash Bang"	\$	\$
25 EA.	Tactical Grenade, "Flash Bang", Small	\$	\$
25 EA.	Tactical Grenade, "Flash Bang", Training	\$	\$
25 EA.	Tactical Grenade, "Flash Bang", Training, Small	\$	\$
30 EA.	CS Grenades Handheld	\$	\$
20 EA.	Stinger Rubber Ball Grenades	\$	\$
20 EA.	Stinger Rubber Ball Grenades w/ OC	\$	\$
Total Section III			\$
GRAND TOTAL Sheriff's Office (Sections I, II and III)			\$

FORM 3

CONTRACT SIGNATURE PAGE

**AMMUNITION FOR PUBLIC SAFETY DEPARTMENTS
(ANNUAL CONTRACT)
RFB No. 20-0062**

THE UNDERSIGNED HEREBY DECLARES THAT HE HAS/THEY HAVE CAREFULLY EXAMINED THE SPECIFICATIONS HEREIN REFERRED TO AND WILL PROVIDE ALL EQUIPMENT, TERMS AND SERVICES TO THE CONSOLIDATED GOVERNMENT OF COLUMBUS, GEORGIA.

Witness as to the signing of the contract

Signature of Authorized Representative Date

Witness as to the signing of the contract

Print Name and Title of Signatory

(Corporate seal, if applicable)

Company Name

Company Ordering Address

Company Payment Address

Contact _____

Contact _____

Email _____

Email _____

Telephone _____

Telephone _____

Fax _____

Fax _____

CONSOLIDATED GOVERNMENT OF COLUMBUS, GEORGIA

Accepted this __ day of _____ 20__

APPROVED AS TO LEGAL FORM:

Isaiah Hugley, City Manager

Clifton C. Fay, City Attorney

ATTEST:

Sandra T. Davis, Clerk of Council

FORM 4

Form **W-9**
(Rev. October 2018)
Department of the Treasury
Internal Revenue Service

Request for Taxpayer Identification Number and Certification

Give Form to the requester. Do not send to the IRS.

▶ Go to www.irs.gov/FormW9 for instructions and the latest information.

	1 Name (as shown on your income tax return). Name is required on this line; do not leave this line blank.	
	2 Business name/disregarded entity name, if different from above	
Print or type. See specific instructions on page 3.	3 Check appropriate box for federal tax classification of the person whose name is entered on line 1. Check only one of the following seven boxes. <input type="checkbox"/> Individual/sole proprietor or single-member LLC <input type="checkbox"/> C Corporation <input type="checkbox"/> S Corporation <input type="checkbox"/> Partnership <input type="checkbox"/> Trust/estate <input type="checkbox"/> Limited liability company. Enter the tax classification (C=C corporation, S=S corporation, P=Partnership) ▶ _____ <small>Note: Check the appropriate box in the line above for the tax classification of the single-member owner. Do not check LLC if the LLC is classified as a single-member LLC that is disregarded from the owner unless the owner of the LLC is another LLC that is not disregarded from the owner for U.S. federal tax purposes. Otherwise, a single-member LLC that is disregarded from the owner should check the appropriate box for the tax classification of its owner.</small> <input type="checkbox"/> Other (see instructions) ▶ _____	4 Exemptions (codes apply only to certain entities, not individuals; see instructions on page 3): Exempt payee code (if any) _____ Exemption from FATCA reporting code (if any) _____ <small>(Applies to accounts maintained outside the U.S.)</small>
	5 Address (number, street, and apt. or suite no.) See instructions.	Requester's name and address (optional)
	6 City, state, and ZIP code	
	7 List account number(s) here (optional)	

Part I Taxpayer Identification Number (TIN)

Enter your TIN in the appropriate box. The TIN provided must match the name given on line 1 to avoid backup withholding. For individuals, this is generally your social security number (SSN). However, for a resident alien, sole proprietor, or disregarded entity, see the instructions for Part I, later. For other entities, it is your employer identification number (EIN). If you do not have a number, see *How to get a TIN*, later.

Note: If the account is in more than one name, see the instructions for line 1. Also see *What Name and Number To Give the Requester* for guidelines on whose number to enter.

Social security number									
or									
Employer identification number									

Part II Certification

Under penalties of perjury, I certify that:

- The number shown on this form is my correct taxpayer identification number (or I am waiting for a number to be issued to me); and
- I am not subject to backup withholding because: (a) I am exempt from backup withholding, or (b) I have not been notified by the Internal Revenue Service (IRS) that I am subject to backup withholding as a result of a failure to report all interest or dividends, or (c) the IRS has notified me that I am no longer subject to backup withholding; and
- I am a U.S. citizen or other U.S. person (defined below); and
- The FATCA code(s) entered on this form (if any) indicating that I am exempt from FATCA reporting is correct.

Certification instructions. You must cross out item 2 above if you have been notified by the IRS that you are currently subject to backup withholding because you have failed to report all interest and dividends on your tax return. For real estate transactions, item 2 does not apply. For mortgage interest paid, acquisition or abandonment of secured property, cancellation of debt, contributions to an individual retirement arrangement (IRA), and generally, payments other than interest and dividends, you are not required to sign the certification, but you must provide your correct TIN. See the instructions for Part II, later.

Sign Here

Signature of U.S. person ▶

Date ▶

General Instructions

Section references are to the Internal Revenue Code unless otherwise noted.

Future developments. For the latest information about developments related to Form W-9 and its instructions, such as legislation enacted after they were published, go to www.irs.gov/FormW9.

Purpose of Form

An individual or entity (Form W-9 requester) who is required to file an information return with the IRS must obtain your correct taxpayer identification number (TIN) which may be your social security number (SSN), individual taxpayer identification number (ITIN), adoption taxpayer identification number (ATIN), or employer identification number (EIN), to report on an information return the amount paid to you, or other amount reportable on an information return. Examples of information returns include, but are not limited to, the following.

- Form 1099-INT (interest earned or paid)

- Form 1099-DIV (dividends, including those from stocks or mutual funds)
 - Form 1099-MISC (various types of income, prizes, awards, or gross proceeds)
 - Form 1099-B (stock or mutual fund sales and certain other transactions by brokers)
 - Form 1099-S (proceeds from real estate transactions)
 - Form 1099-K (merchant card and third party network transactions)
 - Form 1098 (home mortgage interest), 1098-E (student loan interest), 1098-T (tuition)
 - Form 1099-C (canceled debt)
 - Form 1099-A (acquisition or abandonment of secured property)
- Use Form W-9 only if you are a U.S. person (including a resident alien), to provide your correct TIN.
- If you do not return Form W-9 to the requester with a TIN, you might be subject to backup withholding. See What is backup withholding, later.*

By signing the filled-out form, you:

1. Certify that the TIN you are giving is correct (or you are waiting for a number to be issued),
2. Certify that you are not subject to backup withholding, or
3. Claim exemption from backup withholding if you are a U.S. exempt payee. If applicable, you are also certifying that as a U.S. person, your allocable share of any partnership income from a U.S. trade or business is not subject to the withholding tax on foreign partners' share of effectively connected income, and
4. Certify that FATCA code(s) entered on this form (if any) indicating that you are exempt from the FATCA reporting, is correct. See *What is FATCA reporting*, later, for further information.

Note: If you are a U.S. person and a requester gives you a form other than Form W-9 to request your TIN, you must use the requester's form if it is substantially similar to this Form W-9.

Definition of a U.S. person. For federal tax purposes, you are considered a U.S. person if you are:

- An individual who is a U.S. citizen or U.S. resident alien;
- A partnership, corporation, company, or association created or organized in the United States or under the laws of the United States;
- An estate (other than a foreign estate); or
- A domestic trust (as defined in Regulations section 301.7701-7).

Special rules for partnerships. Partnerships that conduct a trade or business in the United States are generally required to pay a withholding tax under section 1446 on any foreign partners' share of effectively connected taxable income from such business. Further, in certain cases where a Form W-9 has not been received, the rules under section 1446 require a partnership to presume that a partner is a foreign person, and pay the section 1446 withholding tax. Therefore, if you are a U.S. person that is a partner in a partnership conducting a trade or business in the United States, provide Form W-9 to the partnership to establish your U.S. status and avoid section 1446 withholding on your share of partnership income.

In the cases below, the following person must give Form W-9 to the partnership for purposes of establishing its U.S. status and avoiding withholding on its allocable share of net income from the partnership conducting a trade or business in the United States.

- In the case of a disregarded entity with a U.S. owner, the U.S. owner of the disregarded entity and not the entity;
- In the case of a grantor trust with a U.S. grantor or other U.S. owner, generally, the U.S. grantor or other U.S. owner of the grantor trust and not the trust; and
- In the case of a U.S. trust (other than a grantor trust), the U.S. trust (other than a grantor trust) and not the beneficiaries of the trust.

Foreign person. If you are a foreign person or the U.S. branch of a foreign bank that has elected to be treated as a U.S. person, do not use Form W-9. Instead, use the appropriate Form W-8 or Form 8233 (see Pub. 515, *Withholding of Tax on Nonresident Aliens and Foreign Entities*).

Nonresident alien who becomes a resident alien. Generally, only a nonresident alien individual may use the terms of a tax treaty to reduce or eliminate U.S. tax on certain types of income. However, most tax treaties contain a provision known as a "saving clause." Exceptions specified in the saving clause may permit an exemption from tax to continue for certain types of income even after the payee has otherwise become a U.S. resident alien for tax purposes.

If you are a U.S. resident alien who is relying on an exception contained in the saving clause of a tax treaty to claim an exemption from U.S. tax on certain types of income, you must attach a statement to Form W-9 that specifies the following five items.

1. The treaty country. Generally, this must be the same treaty under which you claimed exemption from tax as a nonresident alien.
2. The treaty article addressing the income.
3. The article number (or location) in the tax treaty that contains the saving clause and its exceptions.
4. The type and amount of income that qualifies for the exemption from tax.
5. Sufficient facts to justify the exemption from tax under the terms of the treaty article.

Example. Article 20 of the U.S.-China income tax treaty allows an exemption from tax for scholarship income received by a Chinese student temporarily present in the United States. Under U.S. law, this student will become a resident alien for tax purposes if his or her stay in the United States exceeds 5 calendar years. However, paragraph 2 of the first Protocol to the U.S.-China treaty (dated April 30, 1984) allows the provisions of Article 20 to continue to apply even after the Chinese student becomes a resident alien of the United States. A Chinese student who qualifies for this exception (under paragraph 2 of the first protocol) and is relying on this exception to claim an exemption from tax on his or her scholarship or fellowship income would attach to Form W-9 a statement that includes the information described above to support that exemption.

If you are a nonresident alien or a foreign entity, give the requester the appropriate completed Form W-8 or Form 8233.

Backup Withholding

What is backup withholding? Persons making certain payments to you must under certain conditions withhold and pay to the IRS 24% of such payments. This is called "backup withholding." Payments that may be subject to backup withholding include interest, tax-exempt interest, dividends, broker and barter exchange transactions, rents, royalties, nonemployee pay, payments made in settlement of payment card and third party network transactions, and certain payments from fishing boat operators. Real estate transactions are not subject to backup withholding.

You will not be subject to backup withholding on payments you receive if you give the requester your correct TIN, make the proper certifications, and report all your taxable interest and dividends on your tax return.

Payments you receive will be subject to backup withholding if:

1. You do not furnish your TIN to the requester,
2. You do not certify your TIN when required (see the instructions for Part II for details),
3. The IRS tells the requester that you furnished an incorrect TIN,
4. The IRS tells you that you are subject to backup withholding because you did not report all your interest and dividends on your tax return (for reportable interest and dividends only), or
5. You do not certify to the requester that you are not subject to backup withholding under 4 above (for reportable interest and dividend accounts opened after 1983 only).

Certain payees and payments are exempt from backup withholding. See *Exempt payee code*, later, and the separate instructions for the Requester of Form W-9 for more information.

Also see *Special rules for partnerships*, earlier.

What is FATCA Reporting?

The Foreign Account Tax Compliance Act (FATCA) requires a participating foreign financial institution to report all United States account holders that are specified United States persons. Certain payees are exempt from FATCA reporting. See *Exemption from FATCA reporting code*, later, and the instructions for the Requester of Form W-9 for more information.

Updating Your Information

You must provide updated information to any person to whom you claimed to be an exempt payee if you are no longer an exempt payee and anticipate receiving reportable payments in the future from this person. For example, you may need to provide updated information if you are a C corporation that elects to be an S corporation, or if you no longer are tax exempt. In addition, you must furnish a new Form W-9 if the name or TIN changes for the account; for example, if the grantor of a grantor trust dies.

Penalties

Failure to furnish TIN. If you fail to furnish your correct TIN to a requester, you are subject to a penalty of \$50 for each such failure unless your failure is due to reasonable cause and not to willful neglect.

Civil penalty for false information with respect to withholding. If you make a false statement with no reasonable basis that results in no backup withholding, you are subject to a \$500 penalty.

Criminal penalty for falsifying information. Willfully falsifying certifications or affirmations may subject you to criminal penalties including fines and/or imprisonment.

Misuse of TINs. If the requester discloses or uses TINs in violation of federal law, the requester may be subject to civil and criminal penalties.

Specific Instructions

Line 1

You must enter one of the following on this line; do not leave this line blank. The name should match the name on your tax return.

If this Form W-9 is for a joint account (other than an account maintained by a foreign financial institution (FFI)), list first, and then circle, the name of the person or entity whose number you entered in Part I of Form W-9. If you are providing Form W-9 to an FFI to document a joint account, each holder of the account that is a U.S. person must provide a Form W-9.

a. Individual. Generally, enter the name shown on your tax return. If you have changed your last name without informing the Social Security Administration (SSA) of the name change, enter your first name, the last name as shown on your social security card, and your new last name.

Note: ITIN applicant: Enter your individual name as it was entered on your Form W-7 application, line 1a. This should also be the same as the name you entered on the Form 1040/1040A/1040EZ you filed with your application.

b. Sole proprietor or single-member LLC. Enter your individual name as shown on your 1040/1040A/1040EZ on line 1. You may enter your business, trade, or "doing business as" (DBA) name on line 2.

c. Partnership, LLC that is not a single-member LLC, C corporation, or S corporation. Enter the entity's name as shown on the entity's tax return on line 1 and any business, trade, or DBA name on line 2.

d. Other entities. Enter your name as shown on required U.S. federal tax documents on line 1. This name should match the name shown on the charter or other legal document creating the entity. You may enter any business, trade, or DBA name on line 2.

e. Disregarded entity. For U.S. federal tax purposes, an entity that is disregarded as an entity separate from its owner is treated as a "disregarded entity." See Regulations section 301.7701-2(c)(2)(ii). Enter the owner's name on line 1. The name of the entity entered on line 1 should never be a disregarded entity. The name on line 1 should be the name shown on the income tax return on which the income should be reported. For example, if a foreign LLC that is treated as a disregarded entity for U.S. federal tax purposes has a single owner that is a U.S. person, the U.S. owner's name is required to be provided on line 1. If the direct owner of the entity is also a disregarded entity, enter the first owner that is not disregarded for federal tax purposes. Enter the disregarded entity's name on line 2, "Business name/disregarded entity name." If the owner of the disregarded entity is a foreign person, the owner must complete an appropriate Form W-8 instead of a Form W-9. This is the case even if the foreign person has a U.S. TIN.

Line 2

If you have a business name, trade name, DBA name, or disregarded entity name, you may enter it on line 2.

Line 3

Check the appropriate box on line 3 for the U.S. federal tax classification of the person whose name is entered on line 1. Check only one box on line 3.

IF the entity/person on line 1 is a(n) . . .	THEN check the box for . . .
• Corporation	Corporation
• Individual • Sole proprietorship, or • Single-member limited liability company (LLC) owned by an individual and disregarded for U.S. federal tax purposes.	Individual/sole proprietor or single-member LLC
• LLC treated as a partnership for U.S. federal tax purposes, • LLC that has filed Form 8832 or 2553 to be taxed as a corporation, or • LLC that is disregarded as an entity separate from its owner but the owner is another LLC that is not disregarded for U.S. federal tax purposes.	Limited liability company and enter the appropriate tax classification. (P= Partnership; C= C corporation; or S= S corporation)
• Partnership	Partnership
• Trust/estate	Trust/estate

Line 4, Exemptions

If you are exempt from backup withholding and/or FATCA reporting, enter in the appropriate space on line 4 any code(s) that may apply to you.

Exempt payee code.

- Generally, individuals (including sole proprietors) are not exempt from backup withholding.
- Except as provided below, corporations are exempt from backup withholding for certain payments, including interest and dividends.
- Corporations are not exempt from backup withholding for payments made in settlement of payment card or third party network transactions.
- Corporations are not exempt from backup withholding with respect to attorneys' fees or gross proceeds paid to attorneys, and corporations that provide medical or health care services are not exempt with respect to payments reportable on Form 1099-MISC.

The following codes identify payees that are exempt from backup withholding. Enter the appropriate code in the space in line 4.

- 1—An organization exempt from tax under section 501(a), any IRA, or a custodial account under section 403(b)(7) if the account satisfies the requirements of section 401(f)(2)
- 2—The United States or any of its agencies or instrumentalities
- 3—A state, the District of Columbia, a U.S. commonwealth or possession, or any of their political subdivisions or instrumentalities
- 4—A foreign government or any of its political subdivisions, agencies, or instrumentalities
- 5—A corporation
- 6—A dealer in securities or commodities required to register in the United States, the District of Columbia, or a U.S. commonwealth or possession
- 7—A futures commission merchant registered with the Commodity Futures Trading Commission
- 8—A real estate investment trust
- 9—An entity registered at all times during the tax year under the Investment Company Act of 1940
- 10—A common trust fund operated by a bank under section 584(a)
- 11—A financial institution
- 12—A middleman known in the investment community as a nominee or custodian
- 13—A trust exempt from tax under section 664 or described in section 4947

The following chart shows types of payments that may be exempt from backup withholding. The chart applies to the exempt payees listed above, 1 through 13.

IF the payment is for . . .	THEN the payment is exempt for . . .
Interest and dividend payments	All exempt payees except for 7
Broker transactions	Exempt payees 1 through 4 and 6 through 11 and all C corporations. S corporations must not enter an exempt payee code because they are exempt only for sales of noncovered securities acquired prior to 2012.
Barter exchange transactions and patronage dividends	Exempt payees 1 through 4
Payments over \$600 required to be reported and direct sales over \$5,000 ¹	Generally, exempt payees 1 through 5 ²
Payments made in settlement of payment card or third party network transactions	Exempt payees 1 through 4

¹ See Form 1099-MISC, Miscellaneous Income, and its instructions.

² However, the following payments made to a corporation and reportable on Form 1099-MISC are not exempt from backup withholding: medical and health care payments, attorneys' fees, gross proceeds paid to an attorney reportable under section 6045(f), and payments for services paid by a federal executive agency.

Exemption from FATCA reporting code. The following codes identify payees that are exempt from reporting under FATCA. These codes apply to persons submitting this form for accounts maintained outside of the United States by certain foreign financial institutions. Therefore, if you are only submitting this form for an account you hold in the United States, you may leave this field blank. Consult with the person requesting this form if you are uncertain if the financial institution is subject to these requirements. A requester may indicate that a code is not required by providing you with a Form W-9 with "Not Applicable" (or any similar indication) written or printed on the line for a FATCA exemption code.

- A—An organization exempt from tax under section 501(a) or any individual retirement plan as defined in section 7701(a)(37)
- B—The United States or any of its agencies or instrumentalities
- C—A state, the District of Columbia, a U.S. commonwealth or possession, or any of their political subdivisions or instrumentalities
- D—A corporation the stock of which is regularly traded on one or more established securities markets, as described in Regulations section 1.1472-1(c)(1)(i)
- E—A corporation that is a member of the same expanded affiliated group as a corporation described in Regulations section 1.1472-1(c)(1)(i)
- F—A dealer in securities, commodities, or derivative financial instruments (including notional principal contracts, futures, forwards, and options) that is registered as such under the laws of the United States or any state
- G—A real estate investment trust
- H—A regulated investment company as defined in section 851 or an entity registered at all times during the tax year under the Investment Company Act of 1940
- I—A common trust fund as defined in section 584(a)
- J—A bank as defined in section 581
- K—A broker
- L—A trust exempt from tax under section 664 or described in section 4947(a)(1)

M—A tax exempt trust under a section 403(b) plan or section 457(g) plan

Note: You may wish to consult with the financial institution requesting this form to determine whether the FATCA code and/or exempt payee code should be completed.

Line 5

Enter your address (number, street, and apartment or suite number). This is where the requester of this Form W-9 will mail your information returns. If this address differs from the one the requester already has on file, write NEW at the top. If a new address is provided, there is still a chance the old address will be used until the payor changes your address in their records.

Line 6

Enter your city, state, and ZIP code.

Part I. Taxpayer Identification Number (TIN)

Enter your TIN in the appropriate box. If you are a resident alien and you do not have and are not eligible to get an SSN, your TIN is your IRS individual taxpayer identification number (ITIN). Enter it in the social security number box. If you do not have an ITIN, see *How to get a TIN* below.

If you are a sole proprietor and you have an EIN, you may enter either your SSN or EIN.

If you are a single-member LLC that is disregarded as an entity separate from its owner, enter the owner's SSN (or EIN, if the owner has one). Do not enter the disregarded entity's EIN. If the LLC is classified as a corporation or partnership, enter the entity's EIN.

Note: See *What Name and Number To Give the Requester*, later, for further clarification of name and TIN combinations.

How to get a TIN. If you do not have a TIN, apply for one immediately. To apply for an SSN, get Form SS-5, Application for a Social Security Card, from your local SSA office or get this form online at www.SSA.gov. You may also get this form by calling 1-800-772-1213. Use Form W-7, Application for IRS Individual Taxpayer Identification Number, to apply for an ITIN, or Form SS-4, Application for Employer Identification Number, to apply for an EIN. You can apply for an EIN online by accessing the IRS website at www.irs.gov/Businesses and clicking on Employer Identification Number (EIN) under Starting a Business. Go to www.irs.gov/Forms to view, download, or print Form W-7 and/or Form SS-4. Or, you can go to www.irs.gov/OrderForms to place an order and have Form W-7 and/or SS-4 mailed to you within 10 business days.

If you are asked to complete Form W-9 but do not have a TIN, apply for a TIN and write "Applied For" in the space for the TIN, sign and date the form, and give it to the requester. For interest and dividend payments, and certain payments made with respect to readily tradable instruments, generally you will have 60 days to get a TIN and give it to the requester before you are subject to backup withholding on payments. The 60-day rule does not apply to other types of payments. You will be subject to backup withholding on all such payments until you provide your TIN to the requester.

Note: Entering "Applied For" means that you have already applied for a TIN or that you intend to apply for one soon.

Caution: A disregarded U.S. entity that has a foreign owner must use the appropriate Form W-8.

Part II. Certification

To establish to the withholding agent that you are a U.S. person, or resident alien, sign Form W-9. You may be requested to sign by the withholding agent even if item 1, 4, or 5 below indicates otherwise.

For a joint account, only the person whose TIN is shown in Part I should sign (when required). In the case of a disregarded entity, the person identified on line 1 must sign. Exempt payees, see *Exempt payee code*, earlier.

Signature requirements. Complete the certification as indicated in items 1 through 5 below.

1. Interest, dividend, and barter exchange accounts opened before 1984 and broker accounts considered active during 1983. You must give your correct TIN, but you do not have to sign the certification.

2. Interest, dividend, broker, and barter exchange accounts opened after 1983 and broker accounts considered inactive during 1983. You must sign the certification or backup withholding will apply. If you are subject to backup withholding and you are merely providing your correct TIN to the requester, you must cross out item 2 in the certification before signing the form.

3. Real estate transactions. You must sign the certification. You may cross out item 2 of the certification.

4. Other payments. You must give your correct TIN, but you do not have to sign the certification unless you have been notified that you have previously given an incorrect TIN. "Other payments" include payments made in the course of the requester's trade or business for rents, royalties, goods (other than bills for merchandise), medical and health care services (including payments to corporations), payments to a nonemployee for services, payments made in settlement of payment card and third party network transactions, payments to certain fishing boat crew members and fishermen, and gross proceeds paid to attorneys (including payments to corporations).

5. Mortgage interest paid by you, acquisition or abandonment of secured property, cancellation of debt, qualified tuition program payments (under section 529), ABLÉ accounts (under section 529A), IRA, Coverdell ESA, Archer MSA or HSA contributions or distributions, and pension distributions. You must give your correct TIN, but you do not have to sign the certification.

What Name and Number To Give the Requester

For this type of account:	Give name and SSN of:
1. Individual	The individual
2. Two or more individuals (joint account) other than an account maintained by an FFI	The actual owner of the account or, if combined funds, the first individual on the account ¹
3. Two or more U.S. persons (joint account maintained by an FFI)	Each holder of the account
4. Custodial account of a minor (Uniform Gift to Minors Act)	The minor ²
5. a. The usual revocable savings trust (grantor is also trustee) b. So-called trust account that is not a legal or valid trust under state law	The grantor-trustee ¹ The actual owner ¹
6. Sole proprietorship or disregarded entity owned by an individual	The owner ³
7. Grantor trust filing under Optional Form 1099 Filing Method 1 (see Regulations section 1.671-4(b)(2)(i)(A))	The grantor ⁴
For this type of account:	Give name and EIN of:
8. Disregarded entity not owned by an individual	The owner
9. A valid trust, estate, or pension trust	Legal entity ⁴
10. Corporation or LLC electing corporate status on Form 8832 or Form 2553	The corporation
11. Association, club, religious, charitable, educational, or other tax-exempt organization	The organization
12. Partnership or multi-member LLC	The partnership
13. A broker or registered nominee	The broker or nominee

For this type of account:	Give name and EIN of:
14. Account with the Department of Agriculture in the name of a public entity (such as a state or local government, school district, or prison) that receives agricultural program payments	The public entity
15. Grantor trust filing under the Form 1041 Filing Method or the Optional Form 1099 Filing Method 2 (see Regulations section 1.671-4(b)(2)(i)(B))	The trust

¹ List first and circle the name of the person whose number you furnish. If only one person on a joint account has an SSN, that person's number must be furnished.

² Circle the minor's name and furnish the minor's SSN.

³ You must show your individual name and you may also enter your business or DBA name on the "Business name/disregarded entity" name line. You may use either your SSN or EIN (if you have one), but the IRS encourages you to use your SSN.

⁴ List first and circle the name of the trust, estate, or pension trust. (Do not furnish the TIN of the personal representative or trustee unless the legal entity itself is not designated in the account title.) Also see *Special rules for partnerships*, earlier.

*Note: The grantor also must provide a Form W-9 to trustee of trust.

Note: If no name is circled when more than one name is listed, the number will be considered to be that of the first name listed.

Secure Your Tax Records From Identity Theft

Identity theft occurs when someone uses your personal information such as your name, SSN, or other identifying information, without your permission, to commit fraud or other crimes. An identity thief may use your SSN to get a job or may file a tax return using your SSN to receive a refund.

To reduce your risk:

- Protect your SSN,
- Ensure your employer is protecting your SSN, and
- Be careful when choosing a tax preparer.

If your tax records are affected by identity theft and you receive a notice from the IRS, respond right away to the name and phone number printed on the IRS notice or letter.

If your tax records are not currently affected by identity theft but you think you are at risk due to a lost or stolen purse or wallet, questionable credit card activity or credit report, contact the IRS Identity Theft Hotline at 1-800-908-4490 or submit Form 14039.

For more information, see Pub. 5027, Identity Theft Information for Taxpayers.

Victims of identity theft who are experiencing economic harm or a systemic problem, or are seeking help in resolving tax problems that have not been resolved through normal channels, may be eligible for Taxpayer Advocate Service (TAS) assistance. You can reach TAS by calling the TAS toll-free case intake line at 1-877-777-4778 or TTY/TDD 1-800-829-4059.

Protect yourself from suspicious emails or phishing schemes. Phishing is the creation and use of email and websites designed to mimic legitimate business emails and websites. The most common act is sending an email to a user falsely claiming to be an established legitimate enterprise in an attempt to scam the user into surrendering private information that will be used for identity theft.

The IRS does not initiate contacts with taxpayers via emails. Also, the IRS does not request personal detailed information through email or ask taxpayers for the PIN numbers, passwords, or similar secret access information for their credit card, bank, or other financial accounts.

If you receive an unsolicited email claiming to be from the IRS, forward this message to phishing@irs.gov. You may also report misuse of the IRS name, logo, or other IRS property to the Treasury Inspector General for Tax Administration (TIGTA) at 1-800-366-4484. You can forward suspicious emails to the Federal Trade Commission at spam@uce.gov or report them at www.ftc.gov/complaint. You can contact the FTC at www.ftc.gov/idtheft or 877-IDTHEFT (877-438-4338). If you have been the victim of identity theft, see www.IdentityTheft.gov and Pub. 5027.

Visit www.irs.gov/IdentityTheft to learn more about identity theft and how to reduce your risk.

Privacy Act Notice

Section 6109 of the Internal Revenue Code requires you to provide your correct TIN to persons (including federal agencies) who are required to file information returns with the IRS to report interest, dividends, or certain other income paid to you; mortgage interest you paid; the acquisition or abandonment of secured property; the cancellation of debt; or contributions you made to an IRA, Archer MSA, or HSA. The person collecting this form uses the information on the form to file information returns with the IRS, reporting the above information. Routine uses of this information include giving it to the Department of Justice for civil and criminal litigation and to cities, states, the District of Columbia, and U.S. commonwealths and possessions for use in administering their laws. The information also may be disclosed to other countries under a treaty, to federal and state agencies to enforce civil and criminal laws, or to federal law enforcement and intelligence agencies to combat terrorism. You must provide your TIN whether or not you are required to file a tax return. Under section 3406, payers must generally withhold a percentage of taxable interest, dividend, and certain other payments to a payee who does not give a TIN to the payer. Certain penalties may also apply for providing false or fraudulent information.

APPENDIX A

DEMANDSTAR SUBMISSION REQUIREMENTS

Due to the COVID-19 pandemic, the Purchasing Division is suspending the receipt of hard copies of sealed responses and public solicitation openings until further notice. Effective immediately, responses must be submitted via DemandStar.

There is no cost to submit responses electronically through DemandStar; you will only incur a fee if you opt to receive e-notifications directly from DemandStar. You must select "Columbus Consolidated Government" as your free agency (see registration instructions). Solicitations may be accessed thru the DemandStar link that is posted at

https://www.columbusga.gov/finance/purchasing/docs/opportunities/Bid_Opportunities.htm. Per Georgia HB489, the Purchasing Division will continue to post solicitations on the Georgia Procurement Registry. To receive future procurement notifications, you must register with the Team Georgia Marketplace at <http://doas.ga.gov/state-purchasing/suppliers/getting-started-as-a-supplier>.

Excluding responses to Requests for Proposals (RFP), a tabulation of responses will be available on DemandStar shortly after the solicitation closes. The Purchasing Division will also continue to post tabulations at

https://www.columbusga.gov/finance/purchasing/docs/tabulations/bid_tabulations.htm.

Failure to submit electronic responses, via DemandStar, will result in the rejection of your response. Submittals received via U.S. Postal Service, FedEx, UPS, etc., will be returned unopened at the expense of the sender. The Purchasing Division will not accept hand-delivered submittals, and will immediately discard any submittal left in the reception area of the Finance Department.

See following pages for an Electronic Proposal Submission Requirements Checklist and information for DemandStar.

The Purchasing Division sincerely appreciates your cooperation during these unprecedented times.

ELECTRONIC PROPOSAL SUBMISSION CHECKLIST

AMMUNITION (Annual Contract) RFB No. 20-0062

In DemandStar, submit your electronic response as indicated below:

**Vendors shall submit only the required documents listed using the
“Bidder Response ALL Documents” function.
The City will not consider any information submitted as “Supplemental
Documents”**

*Due to file size limitations, please do not re-send the City’s full specifications document
as this information is already on file.*

- 1. COMMUNICATION CONCERNING THIS SOLICITATION (Form 1)
- 2. BID FORM AND PRICING PAGES (Form 2 and Pages 16-22)
- 3. CONTRACT SIGNATURE PAGE (Form 3)
- 4. PRODUCT LITERATURE
- 5. WARRANTY / SHELF LIFE
- 6. SAMPLE INVOICE
- 7. ADDENDA ACKNOWLEDGEMENT
- 8. BUSINESS LICENSE 2020
- 2. W-9 Rev 2018 (Form 4)

Please note: After award of contract by Columbus City Council, awarded vendor will be notified to provide two (2) identical hard copies of submitted proposal with original signatures.

Registering for DemandStar



We are pleased to announce our membership in the DemandStar network. DemandStar is an online marketplace that connects our suppliers directly to the bids, quotes and RFPs that matter to them.

DemandStar is open and accessible to all businesses and provides instant access to our solicitations. By registering for your complimentary DemandStar account, you will receive:

- **Instant** access to bids, quotes and RFPs
- **Automatic** notifications, right to you inbox, of bids that match the commodity codes you select
- The ability to **quickly view** the contractual terms and scope of work
- All the **forms and documents** you need in one place
- Access to **more government bids** in neighboring cities, counties and states

It's EASY! Get started with these 3 easy steps!

1 REGISTER

Go to:
<https://www.demandstar.com/registration>

Create an Account with DemandStar

You are one step away from picking your free government agency

Email Address

Your email address here

Company Name

Your company name here

I accept the DemandStar Terms of Use and Privacy Policy

Next



2019 DemandStar® Corporation. All Rights Reserved.
206.940.0305

2 CHOOSE YOUR FREE AGENCY

Type in the name of the government agency you'd like to add, for example "City of Metropolis" in the Search Box

← Choose Your Free Agency

Receive full access to the government agency of your choice and receive advance notifications of new opportunities.

City of Metropolis 

Narrow down your search by selecting a state and county.

State County
Select State ▼ Select County ▼

- City of Metropolis – Board of Commissioners
- City of Metropolis Purchasing
- Metropolis Technical College

3 CHECK OUT

Check out with your **FREE AGENCY** Registration by clicking "Skip for now" on the page where it gives you options to add additional counties and States

You have chosen Metropolis Technical College as your free agency.
Add additional government agencies below for \$25 per County,
Statewide and National subscriptions available.

My Subscriptions  [0]

Nation (0)

States (0)

Counties (0)

Total	(0 subscriptions)	Your Current Rate
		\$0/year

Proceed to Checkout

→ Skip for Now

SIGN UP

Visit www.demandstar.com



2019 DemandStar® Corporation. All Rights Reserved.
206.940.0305

Responding to an Electronic Bid

5 Step Instructions

Step 1

Many governments are moving toward requiring bid responses electronically. Here are the steps to respond to a bid Electronically.

- Click on the solicitation name



Step 2

Once you are in the solicitation, you will see the Bid Details page that is standard for all solicitations

- When you are ready to submit your bid, click on "Submit E-Bid Proposal"

Bid Details

Agency Name: 48015183
 Bid #/ID: 48015183
 Bid ID: 480151830001
 Bid Type: 48015183
 Bid Start Date: 11/11/2019 10:00:00 AM
 Bid End Date: 11/11/2019 10:00:00 AM
 Bid Name: 48015183

Stage of Work

Documents

Agency Name	Item	Item Number	Item Description
48015183	48015183	48015183	48015183

Publication Info

Bid Kind: None
 Bid Showable: None
 Bid Listing: Library
 Bid Amount: 0.00
 Bid Amount Method: Bid Amount
 Bid Amount Method: Bid Amount
 Bid Amount Method: Bid Amount
 Bid Amount Method: Bid Amount

Publications

Pre-Bid Conference: 48015183

Issuance Code

48015183

Submit E-Bid Proposal

Step 3

Enter information requested page-by-page and you can see what will come next via the menu bar on the left under "E-Bid Progress"

If there is not a total bid amount in your submission, please put "0"

Example: a request for qualifications opportunity may not require a bid amount so vendors will input "0" under "Bid Amount"

E-Bid Response

Contact Information

Company Name: 48015183
 Address 1: 48015183
 Address 2: 48015183
 City: 48015183
 Country: 48015183
 State/Province: 48015183
 County: 48015183
 Postal Code: 48015183
 Phone Number: 48015183
 Extension: 48015183

E-Bid Progress

Contact Information
 Documents of Work
 Bid Amount

Step 4

After you click NEXT on the Contact Information page, you will be directed to enter the documents required. In this example, they only ask for one document, however, in others, they may ask for multiple documents that each need to be uploaded separately.

TIP:
There is a place for you to add "Supplemental", i.e. non-required, documents.

The screenshot shows the 'E-Bid Response' page in the DEMANDSTAR system. On the left, there are sections for 'Bid Details' (Agency Name, Bid Number, Bid Due Date, Bid Opening, Bid Name) and 'E-Bid Progress' (Current Information, Documents Upload, Review Bid). The main area is titled 'E-Bid Response' and contains 'Required Documents' and 'Supplemental Documents' sections. The 'Required Documents' section lists 'Agency Accepted File Formats' with a grid of file types and their counts. Below this is a 'Required Document' section with a table for 'Selected Document' and 'Detailed Document'. The 'Supplemental Documents' section has a text area for 'Document File' and an 'Add Document' button. At the bottom, there are 'Previous' and 'Next' buttons.

Step 5

Review Your E-Bid Response, and if everything is correct, then press "Submit Response"

You are done! And the government to which you've submitted this will download your responses and documents and see the day and time upon which you submitted your proposal.

The screenshot shows the 'Review Your E-Bid Response' page in the DEMANDSTAR system. On the left, there are sections for 'Bid Details' and 'E-Bid Progress'. The main area is titled 'Review Your E-Bid Response' and contains 'Contact Info' (Company Name, Address 1, Address 2, City, State, Zip, County, Phone Code, Email Address, Bid Number, Manager Bio Number) and 'Agency Required Documents' and 'Supplemental Documents' sections. At the bottom, there are 'Previous' and 'Submit Response' buttons. An arrow points to the 'Submit Response' button.

COLUMBUS CONSOLIDATED GOVERNMENT ANNUAL CONTRACT ROUTING MEMORANDUM

DATE: August 19, 2020

SUBJECT: Ammunition (Annual Contract); RFB No. 20-0062

FROM: Patti Postorino, Purchasing Division

Please route for appropriate signatures the one (1) copy of each of the four attached contracts with Dana Safety Supply Inc (Greensboro, NC), Gulf States Distributors Inc (Montgomery, AL), Precision Delta Corporation (Ruleville, MS), and Smyrna Police Distributors Inc (Smyrna, GA) for the estimated annual contract value of \$191,077.40. These firms will provide ammunition and munitions of various types and quantities on an "as needed" basis to Columbus Consolidated Government (the City) to be utilized by the Public Safety Departments.

The term of this contract shall be for two (2) years with the option to renew for three (3) additional twelve-month periods. Contract renewal is contingent upon the mutual agreement of the City and the Contractor.

Funds are budgeted each fiscal year for this on-going expense:

Public Safety Departments: General Fund - Police, Marshal, Muscogee County Prison, and Sheriff - Operating Materials; 0101-400-2900-CTRN-6728, 0101-400-2200-STAF-6728, 0101-530-3000-MRSH-6728, 0101-420-1000-MCCI-6728, 0101-550-1000-SHRF-6728, 0101-550-2300-STRN-6728, 0101-550-2600-JAIL-6728, 0101-550-2100-SPTL-6728.

Council authorized this contract per Resolution No. 223-20, dated August 11, 2020 (copy is attached).

Signatories	Signatures Required (<i>No initials please</i>)	Date
Purchasing Division Manager Signature of Approval		8/19/20
City Attorney: Signature required on Contracts	Form Approved: C.C.F., City Attorney	8/19/20
City Manager: Signature required on Contracts		8/25/2020
Clerk of Council: Signature Required on Contracts & Attest/Seal		8/24/2020
Buyer: Process / Distribute		08/28/2020

After all signatures have been applied, please contact Purchasing Division (ext - 3070) for distribution.

RESOLUTION

NO. 223-20

A RESOLUTION AUTHORIZING THE PURCHASE OF AMMUNITION AND MUNITIONS FROM DANA SAFETY SUPPLY, INC. (GREENSBORO, NC), GULF STATES DISTRIBUTORS, INC. (MONTGOMERY, AL), PRECISION DELTA CORPORATION (RULEVILLE, MS), AND SMYRNA POLICE DISTRIBUTORS, INC. (SMYRNA, GA), ON AN "AS NEEDED" BASIS, FOR THE ESTIMATED ANNUAL CONTRACT VALUE OF \$191,077.40.

WHEREAS, The various types of ammunition include: duty ammunition, practice ammunition, and shotgun ammunition. The munitions supplies include: smoke canisters, tactical grenades, stinger rubber ball grenades, etc. The ammunition and munitions will be used by Columbus Public Safety Departments (Police, Marshal, Muscogee County Prison and Sheriff) and will be purchased on an "as needed" basis; and,

WHEREAS, the initial contract period shall be for two years, with the option to renew for three additional twelve-month periods. Contract renewals will be contingent upon the mutual agreement of the City and the Contractor.

NOW, THEREFORE, THE COUNCIL OF COLUMBUS, GEORGIA, HEREBY RESOLVES AS FOLLOWS:

That the City Manager is hereby authorized to purchase ammunition and munitions from Dana Safety Supply, Inc. (Greensboro, NC), Gulf States Distributors, Inc. (Montgomery, AL), Precision Delta Corporation (Ruleville, MS) and Smyrna Police Distributors, Inc. (Smyrna, GA) on an "as needed" basis, for the estimated annual contract value of \$191,077.40. Funds are budgeted each fiscal year for this on-going expense: General Fund - Police, Marshal, Muscogee County Prison, and Sheriff - Operating Materials; 0101-400-2900-CTRN-6728, 0101-400-2200-STAF-6728, 0101-530-3000-MRSH-6728, 0101-420-1000-MCCI-6728, 0101-550-1000-SHRF-6728, 0101-550-2300-STRN-6728; 0101-550-2600-JAIL-6728, 0101-550-2100-SPTL-6728.

Introduced at a regular meeting of the Council of Columbus, Georgia, held the 11th day of August 2020 and adopted at said meeting by the affirmative vote of eight members of said Council.

Councilor Allen	voting <u> YES </u>
Councilor Barnes	voting <u> ABSENT FOR VOTE </u>
Councilor Crabb	voting <u> YES </u>
Councilor Davis	voting <u> YES </u>
Councilor Garrett	voting <u> YES </u>

Councilor House voting ___ YES ___
Councilor Huff voting ___ YES ___
Councilor Thomas voting ___ YES ___
Councilor Thompson voting ___ YES ___
Councilor Woodson voting _ ABSENT _



Sandra T. Davis
Clerk of Council



B. H. "Skip" Henderson, III
Mayor

CONTRACT

THIS CONTRACT, executed this 25th day of August 2020, by and between the **Consolidated Government of Columbus, Georgia**, hereinafter called the "City", and **Dana Safety Supply, Inc. (Greensboro, NC)**, hereinafter called the "Contractor".

WITNESSETH:

That in consideration of the mutual covenants, obligations, and terms set-forth in the attached proposal and specifications, the parties hereby agree as follows:

1. That the Contractor met all proposal requirements and was evaluated most responsive for providing **Ammunition for Public Safety Departments (Annual Contract)**, per **RFB No. 20-0062**, and was awarded the Contract by Columbus City Council on Tuesday, August 11, 2020, Resolution No. 223-20, for the contract term of two years, beginning October 1, 2020 through September 30, 2022, for furnishing the same in accordance with the specifications prepared by the City and the proposal of the Contractor.
2. The Contractor will, at its own cost and expense, furnish all tools, materials and labor required to be furnished, provide all related services required, and meet all other requirements or conditions imposed, all strictly in accordance with the City's Business Requirements, the City's Request for Bids, dated May 20, 2020 (and all addenda thereto), the Contractor's bid dated June 17, 2020 and the awarded items which are attached hereto as exhibits "A", "B" and "C" respectively, and which are by reference made a part hereof to the same extent as if fully set out herein.
3. On the faithful performance of this Contract by the Contractor, the City will pay the Contractor in accordance with the terms and on the conditions stated in this Contract and the exhibits attached to and by reference made a part hereof.

FORM 3

CONTRACT SIGNATURE PAGE

**AMMUNITION FOR PUBLIC SAFETY DEPARTMENTS
(ANNUAL CONTRACT)
RFB No. 20-0062**

THE UNDERSIGNED HEREBY DECLARES THAT HE HAS/THEY HAVE CAREFULLY EXAMINED THE SPECIFICATIONS HEREIN REFERRED TO AND WILL PROVIDE ALL EQUIPMENT, TERMS AND SERVICES TO THE CONSOLIDATED GOVERNMENT OF COLUMBUS, GEORGIA.

Witness as to the signing of the contract

Witness as to the signing of the contract

(Corporate seal, if applicable)

Signature of Authorized Representative Date

Mark Sevigny, Bid Manager
Print Name and Title of Signatory

Dana Safety Supply
Company Name

Company Ordering Address

Dana Safety Supply

4729 Nelson Brogdon Blvd. Sugar Hill, GA 30518

Contact Mike White

Email mwhite@danasafetysupply.com

Telephone 770-362-8068

Fax 770-381-8360

Company Payment Address

PO Box 117297 Atlanta, GA 30368-7297

Contact Joan Miller

Email jmiller@danasafetysupply.com

Telephone 336-854-5536

Fax N/A

CONSOLIDATED GOVERNMENT OF COLUMBUS, GEORGIA

Accepted this 26th day of August 2020

Isalah Hugley, City Manager

ATTEST:

Sandra T. Davis, Clerk of Council

APPROVED AS TO LEGAL FORM:

Clifton C. Fay, City Attorney

EXECUTION AUTHORIZED

By Resolution No. 223-20

Clerk of Council

<u>VENDOR / ITEMS</u>	<u>EST QTY</u>	<u>UNIT PRICE</u>	<u>TOTAL COST</u>
Dana Safety Supply, Inc. (Greensboro, NC)			
CTS 37mm CS Liquid Barricade Smokeless	10	17.17	\$171.70
CTS 37mm CS Powder Barricade Smokeless	10	19.17	\$191.70
CTS 37mm OC Liquid Barricade Smokeless	10	17.45	\$174.50
CTS Indoor OC Vapor Grenade	5	33.89	\$169.45
CTS CS Baffled Canister Grenade, Pyro Low Flame Potential	5	33.34	\$166.70
40 mm Rotary – OC Muzzle Blast Rounds	200	20.28	\$4,056.00
40 mm Rotary – Long Range CS	100	16.39	\$1,639.00
12gauge Defense Technology Corp Desc Drag Stabilized Bean Bag	100	4.84	\$484.00
40mm - Safe Smoke; 75-150 yards	50	16.12	\$806.00
40mm - Speed - Heat CS: 75-150 yards	70	16.39	\$1,147.30
12 GA Rubber Pellet Round	500	4.28	\$2,140.00
12 GA Super Sock Bean Bag Round	150	4.84	\$726.00
40mm - Multiple Foam Baton, Smokeless; 75-150 yards	20	18.73	\$374.60
Expulsion Grenade, Flameless	25	34.12	\$853.00
Canister, Smoke	80	24.72	\$1,977.60
Canister, Smoke, HC	50	29.62	\$1,481.00
Tactical Grenade, "Flash Bang"	25	36.94	\$923.50
Tactical Grenade, "Flash Bang", Small	25	34.73	\$868.25
Tactical Grenade, "Flash Bang", Training	25	39.45	\$986.25
Tactical Grenade, "Flash Bang", Training, Small	25	38.34	\$958.50
CS Grenades Handheld	30	24.67	\$740.10
Stinger Rubber Ball Grenades	20	38.89	\$777.80
Stinger Rubber Ball Grenades w/ OC	20	38.34	\$766.80
VENDOR TOTAL ESTIMATED ANNUAL CONTRACT VALUE			\$ 22,579.75

EXHIBIT A

Columbus Consolidated Government

Ammunition for Public Safety Departments (Annual Contract)

RFB No. 20-0062

Business Requirements

FORM 4

VC 07669



Form W-9 Request for Taxpayer Identification Number and Certification

1 Name (as shown on your income tax return). Name is required on this line; do not leave this line blank. Dana Safety Supply, Inc.
2 Business name/disregarded entity name, if different from above
3 Check appropriate box for federal tax classification of the person whose name is entered on line 1.
4 Exemptions (codes apply only to certain entities, not individuals; see instructions on page 3).

Part I Taxpayer Identification Number (TIN)
Enter your TIN in the appropriate box. The TIN provided must match the name given on line 1 to avoid backup withholding.
Social security number
Employer identification number

Part II Certification
Under penalties of perjury, I certify that:
1. The number shown on this form is my correct taxpayer identification number (or I am waiting for a number to be issued to me); and
2. I am not subject to backup withholding because: (a) I am exempt from backup withholding, or (b) I have not been notified by the Internal Revenue Service (IRS) that I am subject to backup withholding as a result of a failure to report all interest or dividends, or (c) the IRS has notified me that I am no longer subject to backup withholding; and
3. I am a U.S. citizen or other U.S. person (defined below); and
4. The FATCA code(s) entered on this form (if any) indicating that I am exempt from FATCA reporting is correct.

Sign Here Signature of U.S. person Data 6-12-20

General Instructions
Section references are to the Internal Revenue Code unless otherwise noted.
Future developments. For the latest information about developments related to Form W-9 and its instructions, such as legislation enacted after they were published, go to www.irs.gov/FormW9.
Purpose of Form
An individual or entity (Form W-9 requester) who is required to file an information return with the IRS must obtain your correct taxpayer identification number (TIN) which may be your social security number (SSN), individual taxpayer identification number (ITIN), adoption taxpayer identification number (ATIN), or employer identification number (EIN), to report on an information return the amount paid to you, or other amount reportable on an information return. Examples of information returns include, but are not limited to, the following:
• Form 1099-DIV (dividends, including those from stocks or mutual funds)
• Form 1099-MISC (various types of income, prizes, awards, or gross proceeds)
• Form 1099-B (stock or mutual fund sales and certain other transactions by brokers)
• Form 1099-S (proceeds from real estate transactions)
• Form 1099-K (merchant card and third party network transactions)
• Form 1098 (home mortgage interest), 1098-E (student loan interest), 1098-T (tuition)
• Form 1099-C (canceled debt)
• Form 1099-A (acquisition or abandonment of secured property)
Use Form W-9 only if you are a U.S. person (including a resident alien), to provide your correct TIN.
If you do not return Form W-9 to the requester with a TIN, you might be subject to backup withholding. See What is backup withholding, later.

08/18/2020

Search by TIN, Acct., or Name

Check for imported payees with non-matching TIN data and verify new payees

TIN Matching allows you to verify your Payee data against the IRS TIN Matching database to verify if you have the correct TIN data for your payees.

Sovos can take care of your mismatched TINs & B-Notices

Sovos offers the ability to automatically mail the appropriate forms to your mismatched payees and request corrected information. The responses come directly to you, and the W-9/B-Notice solicitations are saved for your reference in File Manager. Depending on your subscription, additional fees may apply.

[Print & Mail W-9 Solicitations](#)

[Print & Mail B-Notices](#)

The W9 Solicitation button has been disabled as you have already sent your solicitations.

Mismatched Records

TIN	Name

[Download](#)

Individual TIN Lookup

Verify individual Payee Social Security and Employer ID numbers.

Name:

TIN:

[Verify Payee](#)

TIN Status: PASS

OFAC Check: PASS

DMF Check: PASS

[Back to Home](#)

Certificate Must Be Publicly Displayed As Required by Law

CITY OF SUGAR HILL, GEORGIA

OCCUPATION TAX/BUSINESS LICENSE

License Number 2007497

Name of Business Dana Safety Supply, Inc.

Business Address 4729 Nelson Brogdon Blvd
Suite C

Sugar Hill, GA 30518

Tax As P055-POLICE & SAFETY EQUIPMENT SALES & INSTALL

Tax Class 1

This License Tax Receipt Exp 01/31/2021

Date Issued 03/30/2020

The City of Sugar Hill City Clerk shall have the right to suspend any license issued under the ordinance of the City of Sugar Hill, whenever a person, firm, or corporation doing business shall deviate from the normal operation for which the license was purchased or fails in performance to meet the required regulations and code as set forth by the municipality issuing this license, by the Sugar Hill Building Inspection Department, Gwinnett County Police/Fire/Health Department, or violate any law or ordinance of the United States, the State of Georgia, or the County of Gwinnett in pursuant to such business conducted under such license tax, or when it shall be proven before the City Clerk's office that there is a violation of a nuisance law, or when the health, morals, interests, and convenience of the public demand the suspension of such license.

CITY CLERK/COLLECTOR

License is NOT Transferable

EXHIBIT C

Columbus Consolidated Government

Ammunition for Public Safety Departments (Annual Contract)

RFB No. 20-0062

Dana Safety Supply, Inc.

Bid Submission

COLUMBUS CONSOLIDATED GOVERNMENT
Georgia's First Consolidated Government



FINANCE DEPARTMENT
PURCHASING DIVISION

100 TENTH STREET, P. O. Box 1340
COLUMBUS, GEORGIA 31902-1340
706-225-4087, Fax 706-225-3033
Bid Line 706-653-4536
www.columbusga.org

June 10, 2020

Addendum No. 1
Ammunition For Public Safety Departments
(Annual Contract)
RFB No. 20-0062

Submissions should include acknowledgement of receipt for all Addenda:	
Authorized Initials: <u>M</u>	Firm: <u>Dana Safety Supply</u>

Vendors are informed that the above subject RFB is hereby modified, corrected, or supplemented as specified, described and set forth in this Addendum:

QUESTIONS / RESPONSES

Question: *"Is Section III missing from new format? Section III Police.*

Response: The Police Department wishes to receive bids on Section I: Ammunition and Section II: Less Lethal. There is no Section III.

Question: *"Police Dept - Section 1, 5th Item 9mm 147gr Sub-Sonic Do they want JHP – USA9JHP2 or FMJ USA9mm1?"*

Response: The specifications have been changed to add 9mm Winchester 147gr Sub-Sonic FMJ. See Section 1, Item 5., 9mm 147gr Sub-Sonic.

Question: *"Marshal's Office - Section 1 9mm +40 S+W Do they want a "bonded" or "non-bonded"? Section 2 9mm +40 S+W Do they want JHP or FMJ training?"*

Response: The specifications have been changed to add "Bonded". See Section 1, Item 3., 9mm and Item 4., .40 Caliber Federal. The specifications have been changed to add JHP/Ball for practice ammunition. See Section 2, Item 1., 9mm and Item 2., .40 Caliber Federal,

Question: *"Muscogee County Prison - 223 / 5.56mm What grain weight bullet do they want? 65gr or 55gr? Also, do they want a FMJ?"*

Response: The specifications have been changed to add 65gr bullet FMJ, and is now Item 2 in the Section.

Question: *"Sheriff's Office - 12 GA Rifle Slug Do they want a Reduced Recoil or Standard Load?"*

Response: The specifications have been changed to add Reduced Recoil, and is now Item 5 in the Section.

Pricing Pages have been amended for all of the above items.
You must use the attached revised pricing pages.

Please use attached "REVISED" PRICING PAGE for each Public Safety Department. The "Pricing Page" for Police has been revised.

Andrea J. McCorvey
Purchasing Division Manager



FORM 1

COMMUNICATION CONCERNING THIS SOLICITATION

THIS PAGE MUST BE SIGNED AND RETURNED WITH THE VENDOR'S BID/PROPOSAL. FAILURE TO INCLUDE THIS FORM WILL AUTOMATICALLY RENDER VENDOR'S RESPONSE NON-RESPONSIVE.

.....
ALL QUESTIONS OR CLARIFICATIONS CONCERNING THIS SOLICITATION SHALL BE SUBMITTED IN WRITING. THE CITY WILL NOT ORALLY OR TELEPHONICALLY ADDRESS ANY QUESTION OR CLARIFICATION REGARDING BID/PROPOSAL SPECIFICATIONS. IF A VENDOR VISITS OR CALLS THE PURCHASING DIVISION WITH SUCH QUESTIONS, HE OR SHE WILL BE INSTRUCTED TO SUBMIT THE QUESTIONS IN WRITING.

ALL CONTACT CONCERNING THIS SOLICITATION SHALL BE MADE THROUGH THE PURCHASING DIVISION. BIDDERS SHALL NOT CONTACT CITY EMPLOYEES, DEPARTMENT HEADS, USING AGENCIES, EVALUATION COMMITTEE MEMBERS, INCLUDING NON-CCG EMPLOYEES, CONTRACTED PERSONNEL ASSOCIATED WITH THIS PARTICULAR PROJECT (I.E. ARCHITECTS, ENGINEERS, CONSULTANTS), OR ELECTED OFFICIALS WITH QUESTIONS OR ANY OTHER CONCERNS ABOUT THE SOLICITATION. QUESTIONS, CLARIFICATIONS, OR CONCERNS SHALL BE SUBMITTED TO THE PURCHASING DIVISION IN WRITING. IF IT IS NECESSARY THAT A TECHNICAL QUESTION NEEDS ADDRESSING, THE PURCHASING DIVISION WILL FORWARD SUCH TO THE USING AGENCY, WHO WILL SUBMIT A WRITTEN RESPONSE.

THE PURCHASING DIVISION WILL FORWARD WRITTEN RESPONSES TO THE RESPECTIVE BIDDER. IF IT BECOMES NECESSARY TO REVISE ANY PART OF THIS SOLICITATION, A WRITTEN ADDENDUM WILL BE ISSUED TO ALL BIDDERS.

THE CITY IS NOT BOUND BY ANY ORAL REPRESENTATIONS, CLARIFICATIONS, OR CHANGES MADE TO THE WRITTEN SPECIFICATIONS BY CITY EMPLOYEES, UNLESS SUCH CLARIFICATION OR CHANGE IS PROVIDED TO THE BIDDERS IN A WRITTEN ADDENDUM FROM THE PURCHASING MANAGER.

BIDDERS ARE INSTRUCTED TO USE THE ENCLOSED "QUESTION/CLARIFICATION FORM" TO FAX OR EMAIL QUESTION. QUESTIONS AND REQUESTS FOR CLARIFICATION MUST BE SUBMITTED AT LEAST FIVE (5) BUSINESS DAYS BEFORE THE DUE DATE.

ANY REQUEST/CONCERN/PROTEST, AFTER A SOLICITATION HAS CLOSED AND PENDING AWARD, MUST ALSO BE SUBMITTED IN WRITING TO THE PURCHASING DIVISION.

I agree to forward all communication about this solicitation, in writing, to the Purchasing Division. I understand that communication with other persons, other than the Purchasing Division, will render my Bid/Proposal response non-responsive and I will no longer be considered in the solicitation process.

Vendor Name: Dana Safety Supply

Print Name of Authorized Agent: Mark Seviigny

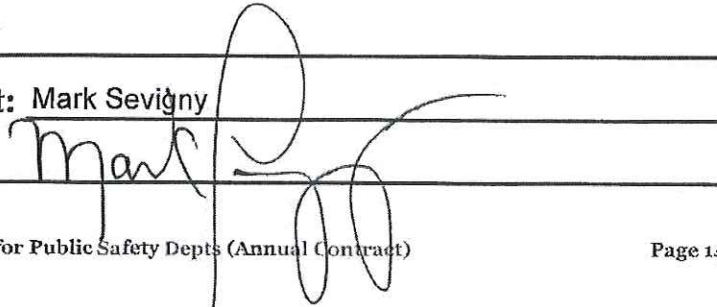
Signature of Authorized Agent: 

FORM 2

BID FORM

**AMMUNITION FOR PUBLIC SAFETY DEPARTMENTS
(ANNUAL CONTRACT)
RFB No. 20-0062**

IMPORTANT INFORMATION:

PLEASE SUBMIT ONE (1) ELECTRONIC BID RESPONSE VIA DEMANDSTAR.

By signing this Bid Form, the authorized representative understands the City reserves the right to request any omitted information, *with the exception of the "Communication Concerning This Solicitation" (Form 1), WHICH DOES NOT AFFECT THE SUBMITTED BID PRICE.* Bidders shall be notified, in writing, and shall have two (2) days, after notification to submit the omitted information. If the omitted information is not received within two (2) days, the Bidder shall be deemed non-responsive and the Bid Submission will be deemed "incomplete". Use the following checklist to verify the items are included in sealed bid:

- Communication Concerning This Solicitation (Form 1) Bid Form (Form 2)
- Pricing Pages (pages 16-20) Contract Signature Page (Form 3) Production Literature
- Warranty & Shelf Life Info Sample Itemized Invoice Business License 2020 W-9 Rev 2018 (Form 4)

Initial below to acknowledge receipt of the following addenda (if any):

Addendum No. 1 ms Addendum No. 2 _____ Addendum No. 3 _____

The undersigned hereby declares that he has/they have carefully examined the specifications herein referred to and will provide all services and terms of the Columbus Consolidated Government.

*All shipping, delivery, and/or freight charges must be included in unit price. Columbus Consolidated Government will pay no additional shipping, delivery and/or freight charges or any other additional fees. Inability to make delivery within specified time will authorize the City to purchase from other sources.

Delivery will be made 30 - 90 day(s) after receipt of purchase order.

Dana Safety Supply

Vendor Business Name

msevigny@danasafetysupply.com

Email Address

Mark Seigny
Authorized Signature

Mark Seigny

Print Name of Signatory

06-12-20

Date

Please circle and initial if Business is {Minority} or {Woman} Owned: _____

If certified as a DBE or WBE, list the certifying agency: _____

Not Minority, Woman or DBE owned (please initial) ms

“REVISED” PRICING PAGE
AMMUNITION FOR PUBLIC SAFETY DEPARTMENTS
(Annual Contract) RFB NO. 20-0062

POLICE DEPARTMENT

VENDOR COMPANY NAME: Dana Safety Supply								
Section I: AMMUNITION								
<u>Item</u>	<u>Caliber or Gauge</u>	<u>Name Brand</u>	<u>Bullet Weight</u>	<u>Notes</u>	<u>Estimated Quantity</u>	<u>Unit Price (Per Round)</u>	<u>Total Price</u>	
1.	12 Gauge	Federal	00 Buck Shot	Reduced Recoil, 9 Pellet	25,000 RDS	\$	\$ No bid	
2.	223	Hornady	55gr	TAP	15,000 RDS	\$	\$	
3.	5.56	NATO	55 gr Ball	Reloaded	75,000 RDS	\$	\$	
4.	38SPL	Precision	148gr	Hollow Base Wadcutter	25,000 RDS	\$	\$	
5.	9MM	Winchester	147gr	Sub-Sonic FMJ	20,000 RDS	\$	\$	
6.	45ACP	Federal	230gr	Ball, Standard Velocity	10,000 RDS	\$	\$	
7.	308	Hornady	168gr	Match	2,000 RDS	\$	\$	
8.	9mm	Reload Federal	124gr	FMJ	20,000 RDS	\$	\$	
9.	223	Federal	55 BT	Gold Match Boat Tail, Hollow Point	3,000 RDS	\$	\$	
10.	9mm	Hornady	135gr	Luger +P Flexlock Critical Duty	10,000 RDS	\$	\$ No bid	
Total Section I							\$	No bid

VENDOR COMPANY NAME: Dana Safety Supply				
Section II: LESS LETHAL				
<u>Item</u>	<u>Description</u>	<u>Estimated Quantity</u>	<u>Unit Price</u>	<u>Total Price</u>
1.	CTS 37mm CS Liquid Barricade Smokeless	10 ea.	\$ 17.17	\$ 171.70
2.	CTS 37mm CS Powder Barricade Smokeless	10 ea.	\$ 19.17	\$ 191.70
3.	CTS 37mm OC Liquid Barricade Smokeless	10 ea.	\$ 17.45	\$ 174.50
4.	CTS Indoor OC Vapor Grenade	5 ea.	\$ 33.89	\$ 169.45
5.	CTS CS Baffled Canister Grenade, Pyro Low Flame Potential	5 ea.	\$ 33.34	\$ 166.70
6.	40mm Rotary – OC Muzzle Blast Rounds	200 ea.	\$ 20.28	\$ 4,056.00
7.	40mm Rotary – Long Range CS	100 ea.	\$ 16.39	\$ 1,639.00
8.	12 gauge Defense Technology Corp. Desc. Drag Stabilized Bean Bag	100 ea.	\$ 4.84	\$ 484.00
Total Section II				\$ 7,053.05
GRAND TOTAL Police Department (Sections I and II)				\$ 7,053.05

“REVISED” PRICING PAGE

AMMUNITION FOR PUBLIC SAFETY DEPARTMENTS (ANNUAL CONTRACT) RFB NO. 20-0062

MARSHAL’S OFFICE

VENDOR COMPANY NAME: Dana Safety Supply							
Section I: AMMUNITION							
Item	Caliber or Gauge	Name Brand	Bullet Weight	Notes	Estimated Quantity	Unit Price (Per Round)	Total Price
1.	12 Gauge	Remington LE	00 Buck, 8 Pellets	Reduced Recoil, PR12BK8-00	1,500 RDS	\$	\$ No bid
2.	223	Remington	55gr	Remington Premier Accutip (PRA223RD)	4,000 RDS	\$	\$
3.	9mm	Federal Tactical	147gr	HST HP (P9HST2) New, Bonded	3,000 RDS	\$	\$
4.	.40 Caliber	Federal Tactical	165gr	Tactical HP (LE40T3), Bonded	1,000 RDS	\$	\$ No bid
Total Section I							\$ No bid
Section II: PRACTICE AMMUNITION							
1.	9mm	Federal	147gr	JHP 850 FPR + P Ball	4,500 RDS	\$	\$ No bid
2.	.40 Caliber	Federal	165gr	JHP/Ball	500 RDS	\$	\$
3.	.223 Caliber	Remington	55gr	Ball L223R3BPLE	8,000 RDS	\$	\$ No bid
Total Section II							\$ No bid
GRAND TOTAL Marshal’s Office (Sections I and II)							\$ No bid

“REVISED” PRICING PAGE

**AMMUNITION FOR PUBLIC SAFETY DEPARTMENTS
(ANNUAL CONTRACT) RFB NO. 20-0062**

MUSCOGEE COUNTY PRISON (MCP)

VENDOR COMPANY NAME: Dana Safety Supply							
PRACTICE AMMUNITION							
<u>Item</u>	<u>Caliber or Gauge</u>	<u>Name Brand</u>	<u>Bullet Weight</u>	<u>Notes</u>	<u>Estimated Quantity</u>	<u>Unit Price (Per Round)</u>	<u>Total Price</u>
1.	9 mill Automatic	Remington- Sig Sauer E9MMB1-50	115gr	FMJ	67,000 RDS	\$.2292	\$ 15,356.40
2.	223 / 556 Rifle	Remington	65gr	FMJ	2,000 RDS	\$	\$ No bid
3.	12 Gauge	Remington	00 Buckshot	Reduced Recoil, 8 Pellet	2,000 RDS	\$	\$ No bid
GRAND TOTAL (MCP)							\$ 15,356.40

“REVISED” PRICING PAGE

AMMUNITION FOR PUBLIC SAFETY DEPARTMENTS (ANNUAL CONTRACT) RFB NO. 20-0062

SHERIFF'S OFFICE

VENDOR COMPANY NAME: Dana Safety Supply							
Section I: AMMUNITION							
<u>Item</u>	<u>Caliber or Gauge</u>	<u>Name Brand</u>	<u>Bullet Weight</u>	<u>Notes</u>	<u>Estimated Quantity</u>	<u>Unit Price (Per Round)</u>	<u>Total Price</u>
1.	.45 ACP	Hornady	220gr +P	FlexLock Critical Duty	13,000 RDS	\$	\$ No bid
2.	9mm	Hornady	135gr	Critical Duty	13,000 RDS	\$	\$
3.	.223 Cal	Hornady	55gr	TAP - Rifle	4,000 RDS	\$	\$
4.	12 Gauge	Remington	8 Pellet	00 Buckshot Reduced Recoil	1,000 RDS	\$	\$
5.	12 Gauge	Remington	1 OZ	Rifle Slug Reduced Recoil	1,000 RDS	\$	\$
6.	.45 ACP	Reload	230gr	FMJ or Jacketed Hollow Point	100,000 RDS	\$	\$
7.	9mm	Reload	115gr	FMJ or Jacketed Hollow Point	100,000 RDS	\$	\$
8.	223 Cal	New	55gr	FMJ or Jacketed Hollow Point	32,000 RDS	\$	\$ No bid
Total Section I							\$ No bid

“REVISED” PRICING PAGE

AMMUNITION FOR PUBLIC SAFETY DEPARTMENTS (ANNUAL CONTRACT) RFB NO. 20-0062

SHERIFF’S OFFICE

VENDOR COMPANY NAME: Dana Safety Supply				
Section II: MUNITIONS				
<u>Item</u>	<u>Description</u>	<u>Estimated Quantity</u>	<u>Unit Price</u>	<u>Total Price</u>
<i>“All munitions that have a fuse with a pull ring must be equipped with a pull ring safety clip.”</i>				
1.	40mm Safe Smoke; 75 – 150 yards	50 ea.	\$ 16.12	\$ 806.00
2.	40mm Speed – Heat CS; 75 – 150 yards	70 ea.	\$ 16.39	\$ 1,147.30
3.	12 GA Diversionary Aerial Round	100 ea.	\$ No bid	\$ No bid
4.	12 GA Rubber Pellet Round	500 ea.	\$ 4.28	\$ 2,140.00
5.	12 GA Super Sock Bean Bag Round	150 ea.	\$ 4.84	\$ 726.00
6.	40mm Multiple Foam Baton, Smokeless 75-150 YD	20 ea.	\$ 18.73	\$ 374.60
Total Section II				\$ 5,193.90
Section III: HAND DEPLOYABLE MUNITIONS				
<i>“All munitions that have a fuse with a pull ring must be equipped with a pull ring safety clip.”</i>				
1.	Rubber Ball, w/ White Smoke	100 ea.	\$ No bid	\$ No bid
2.	Expulsion Grenade, Flameless	25 ea.	\$ 34.12	\$ 853.00
3.	Canister, Smoke	80 ea.	\$ 24.72	\$ 1,977.60
4.	Canister, Smoke, HC	50 ea.	\$ 29.62	\$ 1,481.00
5.	Canister, Smoke, Pocket	130 ea.	\$ No bid	\$ No bid
6.	Canister, CN	30 ea.	\$ No bid	\$ No bid
7.	Canister, OC	80 ea.	\$ No bid	\$ No bid
8.	Tactical Grenade, “Flash Bang”	25 ea.	\$ 36.94	\$ 923.50
9.	Tactical Grenade, “Flash Bang”, Small	25 ea.	\$ 34.73	\$ 868.25
10.	Tactical Grenade, “Flash Bang”, Training	25 ea.	\$ 39.45	\$ 986.25
11.	Tactical Grenade, “Flash Bang”, Training, Small	25 ea.	\$ 38.34	\$ 958.50
12.	CS Grenades Handheld	30 ea.	\$ 24.67	\$ 740.10
13.	Stinger Rubber Ball Grenades	20 ea.	\$ 38.89	\$ 777.80
14.	Stinger Rubber Ball Grenades w/ OC	20 ea.	\$ 38.34	\$ 766.80
Total Section III				\$ 10,332.80
GRAND TOTAL Sheriff’s Office (Sections I, II and III)				\$ 15,526.70

FORM 3

CONTRACT SIGNATURE PAGE

**AMMUNITION FOR PUBLIC SAFETY DEPARTMENTS
(ANNUAL CONTRACT)
RFB No. 20-0062**

THE UNDERSIGNED HEREBY DECLARES THAT HE HAS/THEY HAVE CAREFULLY EXAMINED THE SPECIFICATIONS HEREIN REFERRED TO AND WILL PROVIDE ALL EQUIPMENT, TERMS AND SERVICES TO THE CONSOLIDATED GOVERNMENT OF COLUMBUS, GEORGIA.

Witness as to the signing of the contract

Signature of Authorized Representative Date

Witness as to the signing of the contract

Mark Sevigny, Bid Manager
Print Name and Title of Signatory

(Corporate seal, if applicable)

Dana Safety Supply
Company Name

Company Ordering Address

Company Payment Address

Dana Safety Supply

PO Box 117297 Atlanta, GA 30368-7297

4729 Nelson Brogdon Blvd. Sugar Hill, GA 30518

Contact Mike White

Contact Joan Miller

Email mwhite@danasafetysupply.com

Email jmill@danasafetysupply.com

Telephone 770-362-8068

Telephone 336-854-5536

Fax 770-381-8360

Fax N/A

CONSOLIDATED GOVERNMENT OF COLUMBUS, GEORGIA

Accepted this ___ day of _____ 20__

APPROVED AS TO LEGAL FORM:

Isaiah Hugley, City Manager

Clifton C. Fay, City Attorney

ATTEST:

Sandra T. Davis, Clerk of Council

Invoice

DANA SAFETY SUPPLY, DMY
 4809 KOGER BLVD
 GREENSBORO, NC 27407
 USA
 Telephone: 800-845-0405

Invoice No.	9333328-A
Customer No.	COLUMBUS

Bill To

COLUMBUS CONSOLIDATED GOVERNMENT
 510 10TH STREET
 COLUMBUS, GA 31901

Ship To

COLUMBUS CONSOLIDATED GOVERNMENT
 510 10TH STREET
 COLUMBUS, GA 31901

Contact:
 Telephone:
 E-mail:

Contact:
 Telephone:
 E-mail:

Invoice Date	Order Date	SO Number	Ordered By	Customer PO Number	Payment Method
06/16/20	06/16/20				NET30
Warehouse	Ship Via	F.O.B.	Salesperson	Resale Number	
ATLA	GROUND	PPAY & ADD TO INVOICE	MARK SEVIGNY- GEORGIA		
Order Quantity	Ship Quantity	Tax	Item Number / Description	Unit Price	Extended Price
1	1	Y	MISC U of M: EACH CTS NON LETHAL 5% OFF	0.0000	0.00
1	1	Y	MISC U of M: EACH SIG SAUER AMMO 1% OFF FET OUT	0.0000	0.00
Remit To: Dana Safety Supply, Inc. P.O. Box 117297 Atlanta, GA 30368-7297					
* All Return Merchandise Requires Prior Approval. * Return Merchandise can be subject to a 20% restocking charge. * Claims against this Invoice for Price and/or Quantity must be filed in writing within 30 days of invoice date. * A Finance Charge of 1.5% per month (18% annual rate) will be added to all invoices that are 30 days beyond the invoice date.					

Print Date	06/16/20
Print Time	10:50:21 AM
Page No.	1

Total Paid	0.00
Balance Due	0.00
Due Date	07/16/20

Subtotal	0.00
Freight	0.00
Invoice Total	0.00

Printed By: JOAN MILLER

ELECTRONIC PROPOSAL SUBMISSION CHECKLIST

AMMUNITION (Annual Contract) RFB No. 20-0062

In DemandStar, submit your electronic response as indicated below:

**Vendors shall submit only the required documents listed using the
“Bidder Response ALL Documents” function.
The City will not consider any information submitted as “Supplemental
Documents”**

*Due to file size limitations, please do not re-send the City's full specifications document
as this information is already on file.*

- 1. COMMUNICATION CONCERNING THIS SOLICITATION (Form 1)
- 2. BID FORM AND PRICING PAGES (Form 2 and Pages 16-22)
- 3. CONTRACT SIGNATURE PAGE (Form 3)
- 4. PRODUCT LITERATURE
- 5. WARRANTY / SHELF LIFE
- 6. SAMPLE INVOICE
- 7. ADDENDA ACKNOWLEDGEMENT
- 8. BUSINESS LICENSE 2020
- 2. W-9 Rev 2018 (Form 4)

***Please note: After award of contract by Columbus City Council,
awarded vendor will be notified to provide two (2) identical hard copies
of submitted proposal with original signatures.***



PRODUCT SPECIFICATIONS

MODEL No.	DESCRIPTION:
4320	40MM CN Liquid Barricade, Spin Stabilized
4330	40MM CS Liquid Barricade, Spin Stabilized
4340	40MM OC Liquid Barricade, Spin Stabilized
	Revision E 10/18

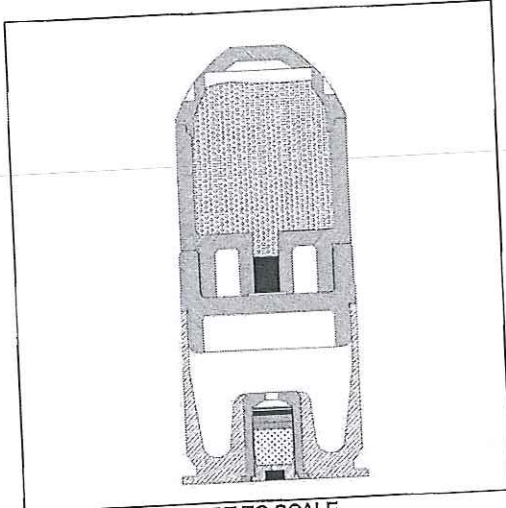

NOT TO SCALE

WARNING: CSI manufactures a variety of CTS less lethal products which are under pressure, pyrotechnic, incendiary, emit projectiles, generate smoke, or are explosive in nature. When used in accordance with CTS training guidelines and the individual agency's policy, they are intended to cause varying degrees of pain and injury, which are temporary. These products are restricted to law enforcement, corrections, and military personnel and are used to gain compliance, disperse crowds, restore order, or temporarily incapacitate dangerous persons. In rare circumstances, if used incorrectly, CTS less-lethal products may cause damage to property, serious bodily injury or death. Therefore, any person using the force option depicted on this page should receive proper training to ensure the safest and most effective use.

PHYSICAL & OPERATIONAL	
Type	Barricade Penetrating Munitions
Caliber	40MM
Weapon Compatibility	All 40MM Launchers, M203, M79 and Multi-Launcher Type
Cartridge Length	4.1" (104.14 mm)
Effective Range*	50 Yards (45 M)
Muzzle Velocity	400-425 ft./sec
Discharge Time	Instantaneous on Impact
Warranty	5 Years from Shipment Date

All specifications are average and are subject to change without notice. All performance specifications are based on testing conducted in Jamestown, PA USA, At an elevation of 1,058 feet above sea level at ambient temperature conditions.

SHIPPING INFORMATION	
Proper Shipping Name	Ammunition Smoke
UN Number	0303
Hazard Class	1.4G
Labels Required	Explosive 1.4G
Quantity Per Package	96 Cartridges
Total Package Weight	45 lb.
Package Type	Drum UN1A2/Y36/S
Package Dimensions	19 x 12 (7 gal. drum) also used for overnight packages
Net Explosive Weight	0.52 gm per unit

*Effectiveness is dependent upon the type of weapon, angle of impact, environmental conditions, and the type of the intermediate barrier. The greatest probability for penetration occurs when the projectile impacts 90° perpendicular to the intermediate barrier. General usage in tactical situations involves intermediate barriers, such as single pane exterior windows, vehicle windows, pressed wood particle doors, 1-2 layers of wallboard, and interior hollow core doors.

CAUTION: These less-lethal munitions are designed for specific tactical situations. One must be trained specifically in the deployment of barricade penetrating munitions and exercise extreme care and caution to minimize the possibility of this projectile striking a human opposite the barrier.

CTS is a Division of Combined Systems, Inc.
 388 Kinsman Rd.
 Jamestown, PA 16134 USA
 TEL (724) 932-2177
 FAX (724) 932-2166
 EMAIL Sales@combinedsystems.com
www.combinedsystems.com





PRODUCT SPECIFICATIONS

MODEL No.	DESCRIPTION:
5210B	Smoke Baffled Canister Grenade, Low Flame Potential
5220B	CN Baffled Canister Grenade, Low Flame Potential
5230B	CS Baffled Canister Grenade, Low Flame Potential
	Revision C 10/18

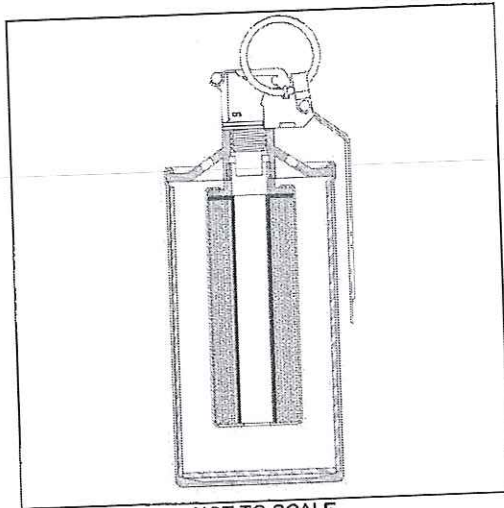

NOT TO SCALE

WARNING: CSI manufactures a variety of CTS less lethal products which are under pressure, pyrotechnic, incendiary, emit projectiles, generate smoke, or are explosive in nature. When used in accordance with CTS training guidelines and the individual agency's policy, they are intended to cause varying degrees of pain and injury, which are temporary. These products are restricted to law enforcement, corrections, and military personnel and are used to gain compliance, disperse crowds, restore order, or temporarily incapacitate dangerous persons. In rare circumstances, if used incorrectly, CTS less-lethal products may cause damage to property, serious bodily injury or death. Therefore, any person using the force option depicted on this page should receive proper training to ensure the safest and most effective use.

PHYSICAL & OPERATIONAL	
Type	Irritant & Smoke Pyrotechnic Grenades
Diameter	2.60" (66 mm)
Length	6.20" (157 mm)
Fuze Type	Model 201
Fuze Delay	1.5 +/- 0.3 sec. average
Launchable	Yes
Discharge Time	20 - 40 Seconds
Emission Ports	4
Overall Weight	395 gm
Warranty	5 Years From Shipment Date
<p>All specifications are average and are subject to change without notice. All performance specifications are based on testing conducted in Jamestown, PA USA, At an elevation of 1,058 feet above sea level at ambient temperature conditions.</p>	

SHIPPING INFORMATION	
Proper Shipping Name	Ammunition, Smoke
UN Number	0303
Hazard Class	1.4G
Labels Required	Explosive 1.4G
Quantity Per Package	24 Grenades
Total Package Weight	31 lb.
Package Type	UN Specification 1A2/Y36/S Metal Drum with Lever Lock Lid
Package Dimensions	19x12 (7 gal. drum also used for overnight packages)
Net Explosive Weight	85 gm per unit



CTS is a Division of Combined Systems, Inc.
 388 Kinsman Rd.
 Jamestown, PA 16134 USA
 TEL (724) 932-2177
 FAX (724) 932-2166
 EMAIL Sales@combinedsystems.com
www.combinedsystems.com

MODEL No.	DESCRIPTION:
4620	40MM CN Muzzle Blast
4630	40MM CS Muzzle Blast
4640	40MM OC Muzzle Blast
Revision C 10/18	

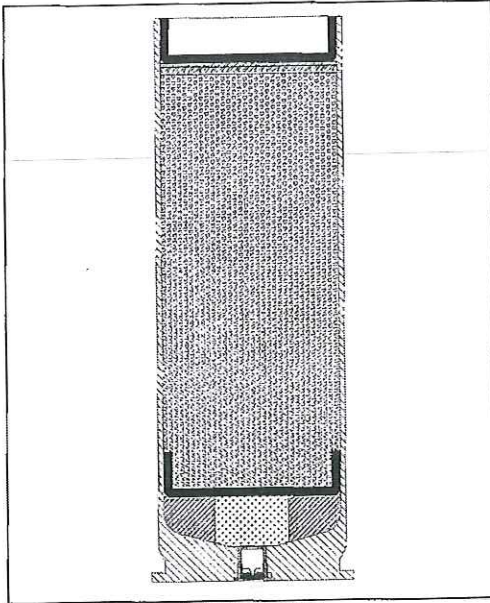

NOT TO SCALE

WARNING: CSI manufactures a variety of CTS less lethal products which are under pressure, pyrotechnic, incendiary, emit projectiles, generate smoke, or are explosive in nature. When used in accordance with CTS training guidelines and the individual agency's policy, they are intended to cause varying degrees of pain and injury, which are temporary. These products are restricted to law enforcement, corrections, and military personnel and are used to gain compliance, disperse crowds, restore order, or temporarily incapacitate dangerous persons. In rare circumstances, if used incorrectly, CTS less-lethal products may cause damage to property, serious bodily injury or death. Therefore, any person using the force option depicted on this page should receive proper training to ensure the safest and most effective use.

PHYSICAL & OPERATIONAL	
Type	Powder Blast Dispersion Munitions
Caliber	40MM
Weapon Compatibility	All 40MM Launchers, M203, M79 and Multi-Launcher Type
Cartridge Length	4.8" (122 mm)
Effective Range*	10-30 Feet (3-9 M)
Overall Weight	140 gm
Discharge Time	Instantaneous
Warranty	5 Years from Shipment Date
<p>All specifications are average and are subject to change without notice. All performance specifications are based on testing conducted in Jamestown, PA USA, At an elevation of 1,058 feet above sea level at ambient temperature conditions.</p>	

SHIPPING INFORMATION	
Proper Shipping Name	Ammunition, Tear-Producing
UN Number	0301
Hazard Class	1.4G, 6.1, 8
Labels Required	Explosive, Corrosive, Poison
Quantity Per Package	96
Total Package Weight	25.4 lb.
Package Type	UN Specification 1A2/Y36/S Metal Drum with Lever Lock Lid
Package Dimensions	12" Diameter x 19" Height
Net Explosive Weight	.45 gm per unit

*Effective range is dependent upon environmental factors, especially wind. Operators should ensure that the wind or even a breeze is at their back prior to deployment.

MODEL No.	DESCRIPTION:
4210	40MM White Smoke
4220	40MM CN Smoke
4230	40MM CS Smoke
Revision C 9/18	

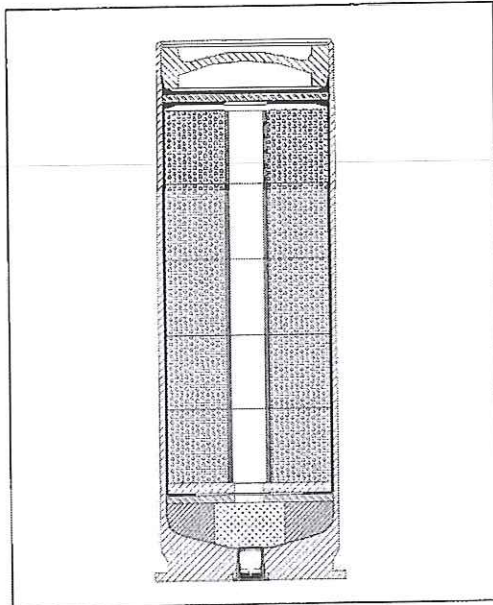

NOT TO SCALE

WARNING: CSI manufactures a variety of CTS less lethal products which are under pressure, pyrotechnic, incendiary, emit projectiles, generate smoke, or are explosive in nature. When used in accordance with CTS training guidelines and the individual agency's policy, they are intended to cause varying degrees of pain and injury, which are temporary. These products are restricted to law enforcement, corrections, and military personnel and are used to gain compliance, disperse crowds, restore order, or temporarily incapacitate dangerous persons. In rare circumstances, if used incorrectly, CTS less-lethal products may cause damage to property, serious bodily injury or death. Therefore, any person using the force option depicted on this page should receive proper training to ensure the safest and most effective use.

PHYSICAL & OPERATIONAL	
Type	Irritant & Smoke Pyrotechnic Projectiles
Caliber	40MM
Weapon Compatibility	All 40MM Launchers, M203, M79 and Multi-Launcher Type
Cartridge Length	4.8" (122 mm)
Effective Range*	110 yards (100 m)
Overall Weight	200 gm
Discharge Time	20-40 Seconds
Warranty	5 Years from Shipment Date
<p>All specifications are average and are subject to change without notice. All performance specifications are based on testing conducted in Jamestown, PA USA, At an elevation of 1,058 feet above sea level at ambient temperature conditions.</p>	

SHIPPING INFORMATION	
Proper Shipping Name	Ammunition Smoke
UN Number	0303
Hazard Class	1.4G
Labels Required	Explosive 1.4G
Quantity Per Package	96 Cartridges
Total Package Weight	53 lb.
Package Type	UN Specification 1A2/Y36/S Metal Drum with Lever Lock Lid
Package Dimensions	19 x 12 (7 gal. drum, also used for overnight packages)
Net Explosive Weight	87.40gm per unit

*Effective range is dependent upon environmental factors, especially wind.



PRODUCT SPECIFICATIONS

MODEL No.	DESCRIPTION:
2581	12GA Super-Sock® Bean Bag
	Revision C 9/18

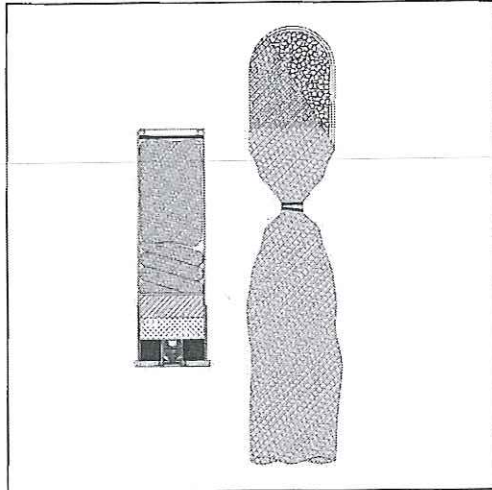

NOT TO SCALE

WARNING: CSI manufactures a variety of CTS less lethal products which are under pressure, pyrotechnic, incendiary, emit projectiles, generate smoke, or are explosive in nature. When used in accordance with CTS training guidelines and the individual agency's policy, they are intended to cause varying degrees of pain and injury, which are temporary. These products are restricted to law enforcement, corrections, and military personnel and are used to gain compliance, disperse crowds, restore order, or temporarily incapacitate dangerous persons. In rare circumstances, if used incorrectly, CTS less-lethal products may cause damage to property, serious bodily injury or death. Therefore, any person using the force option depicted on this page should receive proper training to ensure the safest and most effective use.

PHYSICAL & OPERATIONAL	
Type	Point Control Impact Munitions
Caliber	12 GA
Weapon Compatibility	Cylinder Bore, 18" Barrel Minimum
Cartridge Length	2.40" (61 mm)
Effective Range*	75' (25 M)
Projectile Weight	40 gm
Projectile Material	Shot Filled Ballistic Fiber
Overall Weight	51 gm
Velocity	270-290 ft./sec
Warranty	5 Years from Shipment Date
<p>All specifications are average and are subject to change without notice. All performance specifications are based on testing conducted in Jamestown, PA USA, At an elevation of 1,058 feet above sea level at ambient temperature conditions.</p>	

SHIPPING INFORMATION	
Proper Shipping Name	Cartridges for Weapons Inert Projectile
UN Number	0012
Hazard Class	1.4 S
Labels Required	Explosive 1.4S
Quantity Per Package	5 Cartridges in Cardboard Box
Total Package Weight	50 lb. (400 Cartridges)
Package Type	Fiberboard Box
Package Dimensions	17 x11 x 6
Net Explosive Weight	.23 gm per unit

*The Model 2581 Super-Sock® is in its deployed state immediately upon exiting the barrel. It does not require a minimum range to "unfold" or "stabilize." The Super-Sock® is an aerodynamic projectile. However, accuracy is relative to the shotgun, barrel length, environmental conditions, and the operator. The Super-Sock® is very accurate. However, effectiveness depends on many variable, such as distance, clothing, stature, and the point where the projectile impacts.

CAUTION: Shots to the head, neck, thorax, heart, or spine can result in fatal or serious injury.



CTS is a Division of Combined Systems, Inc.
 388 Kinsman Rd.
 Jamestown, PA 16134 USA
 TEL (724) 932-2177
 FAX (724) 932-2166
 EMAIL Sales@combinedsystems.com
www.combinedsystems.com

MODEL No.	DESCRIPTION:
4210	40MM White Smoke
4220	40MM CN Smoke
4230	40MM CS Smoke
Revision C 9/18	

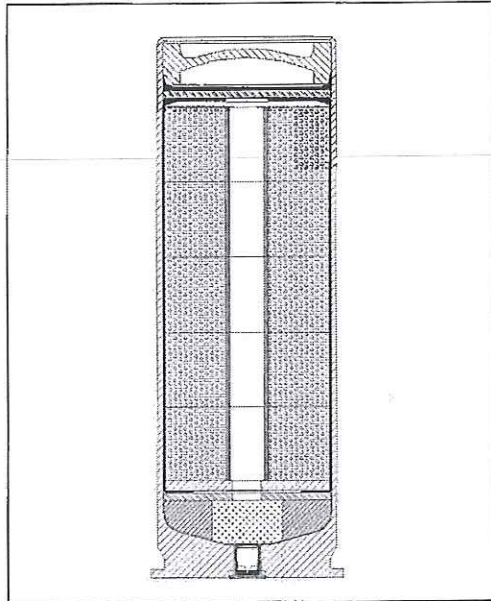

NOT TO SCALE

WARNING: CSI manufactures a variety of CTS less lethal products which are under pressure, pyrotechnic, incendiary, emit projectiles, generate smoke, or are explosive in nature. When used in accordance with CTS training guidelines and the individual agency's policy, they are intended to cause varying degrees of pain and injury, which are temporary. These products are restricted to law enforcement, corrections, and military personnel and are used to gain compliance, disperse crowds, restore order, or temporarily incapacitate dangerous persons. In rare circumstances, if used incorrectly, CTS less-lethal products may cause damage to property, serious bodily injury or death. Therefore, any person using the force option depicted on this page should receive proper training to ensure the safest and most effective use.

PHYSICAL & OPERATIONAL	
Type	Irritant & Smoke Pyrotechnic Projectiles
Caliber	40MM
Weapon Compatibility	All 40MM Launchers, M203, M79 and Multi-Launcher Type
Cartridge Length	4.8" (122 mm)
Effective Range*	110 yards (100 m)
Overall Weight	200 gm
Discharge Time	20-40 Seconds
Warranty	5 Years from Shipment Date
<p>All specifications are average and are subject to change without notice. All performance specifications are based on testing conducted in Jamestown, PA USA, At an elevation of 1,058 feet above sea level at ambient temperature conditions.</p>	

SHIPPING INFORMATION	
Proper Shipping Name	Ammunition Smoke
UN Number	0303
Hazard Class	1.4G
Labels Required	Explosive 1.4G
Quantity Per Package	96 Cartridges
Total Package Weight	53 lb.
Package Type	UN Specification 1A2/Y36/S Metal Drum with Lever Lock Lid
Package Dimensions	19 x 12 (7 gal. drum, also used for overnight packages)
Net Explosive Weight	87.40gm per unit

*Effective range is dependent upon environmental factors, especially wind.

MODEL No.	DESCRIPTION:
4210	40MM White Smoke
4220	40MM CN Smoke
4230	40MM CS Smoke
	Revision C 9/18

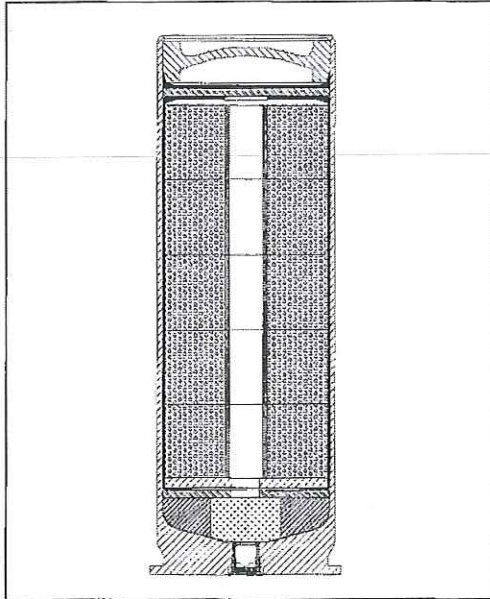

NOT TO SCALE

WARNING: CSI manufactures a variety of CTS less lethal products which are under pressure, pyrotechnic, incendiary, emit projectiles, generate smoke, or are explosive in nature. When used in accordance with CTS training guidelines and the individual agency's policy, they are intended to cause varying degrees of pain and injury, which are temporary. These products are restricted to law enforcement, corrections, and military personnel and are used to gain compliance, disperse crowds, restore order, or temporarily incapacitate dangerous persons. In rare circumstances, if used incorrectly, CTS less-lethal products may cause damage to property, serious bodily injury or death. Therefore, any person using the force option depicted on this page should receive proper training to ensure the safest and most effective use.

PHYSICAL & OPERATIONAL

Type	Irritant & Smoke Pyrotechnic Projectiles
Caliber	40MM
Weapon Compatibility	All 40MM Launchers, M203, M79 and Multi-Launcher Type
Cartridge Length	4.8" (122 mm)
Effective Range*	110 yards (100 m)
Overall Weight	200 gm
Discharge Time	20-40 Seconds
Warranty	5 Years from Shipment Date

All specifications are average and are subject to change without notice. All performance specifications are based on testing conducted in Jamestown, PA USA, At an elevation of 1,058 feet above sea level at ambient temperature conditions.

SHIPPING INFORMATION

Proper Shipping Name	Ammunition Smoke
UN Number	0303
Hazard Class	1.4G
Labels Required	Explosive 1.4G
Quantity Per Package	96 Cartridges
Total Package Weight	53 lb.
Package Type	UN Specification 1A2/Y36/S Metal Drum with Lever Lock Lid
Package Dimensions	19 x 12 (7 gal. drum, also used for overnight packages)
Net Explosive Weight	87.40gm per unit

*Effective range is dependent upon environmental factors, especially wind.

MODEL No.	DESCRIPTION:
2552	12GA .31Cal Sting-Balls
	Revision C 9/18

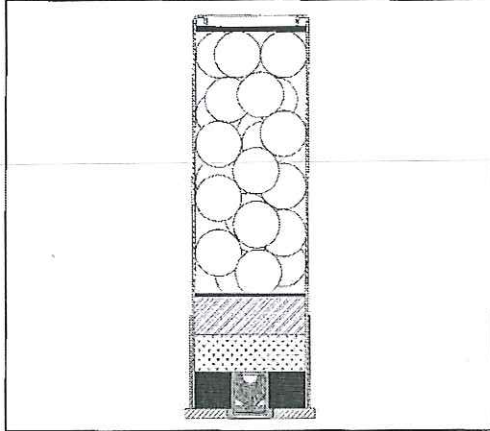

NOT TO SCALE

WARNING: CSI manufactures a variety of CTS less lethal products which are under pressure, pyrotechnic, incendiary, emit projectiles, generate smoke, or are explosive in nature. When used in accordance with CTS training guidelines and the individual agency's policy, they are intended to cause varying degrees of pain and injury, which are temporary. These products are restricted to law enforcement, corrections, and military personnel and are used to gain compliance, disperse crowds, restore order, or temporarily incapacitate dangerous persons. In rare circumstances, if used incorrectly, CTS less-lethal products may cause damage to property, serious bodily injury or death. Therefore, any person using the force option depicted on this page should receive proper training to ensure the safest and most effective use.

PHYSICAL & OPERATIONAL	
Type	Crowd Dispersal Impact Munition
Caliber	12 GA
Weapon Compatibility	Cylinder Bore, 18" Barrel Minimum
Cartridge Length	2.4" (61 mm)
Effective Range*	25' (7.6 M)
Overall Weight	18 gm
Projectile Material	Rubber
Velocity	375-450 ft./sec
Warranty	5 Years from Shipment Date
<p>All specifications are average and are subject to change without notice. All performance specifications are based on testing conducted in Jamestown, PA USA, At an elevation of 1,058 feet above sea level at ambient temperature conditions.</p>	

SHIPPING INFORMATION	
Proper Shipping Name	Cartridges for Weapons, Inert Projectile
UN Number	0012
Hazard Class	1.4 S
Labels Required	Explosive 1.4S
Quantity Per Package	5 Cartridges in Plastic Bag
Total Package Weight	18lb. (400 Cartridges)
Package Type	Fiberboard Box
Package Dimensions	17 x 11 x 6
Net Explosive Weight	.29 gm per unit

*The 2552 Sting-Ball launches multiple rubber projectiles (on the average 18) to affect a general area. The shot pattern of the projectiles will increase over distance. General accuracy and effectiveness are relative to the shotgun, barrel length, environmental conditions, the operator, distance, thickness of clothing and the stature of the human target.

CAUTION: Dispersion of the projectiles creates a greater risk of eye injury, and requires the operator to target a low point of impact, below the belt line, on human targets.

MODEL No.	DESCRIPTION:
2581	12GA Super-Sock® Bean Bag
	Revision C 9/18

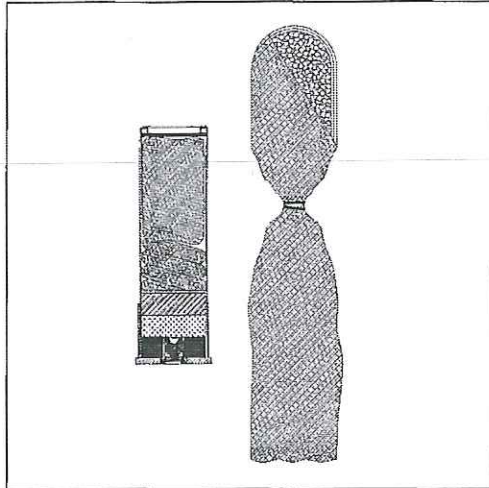

NOT TO SCALE

WARNING: CSI manufactures a variety of CTS less lethal products which are under pressure, pyrotechnic, incendiary, emit projectiles, generate smoke, or are explosive in nature. When used in accordance with CTS training guidelines and the individual agency's policy, they are intended to cause varying degrees of pain and injury, which are temporary. These products are restricted to law enforcement, corrections, and military personnel and are used to gain compliance, disperse crowds, restore order, or temporarily incapacitate dangerous persons. In rare circumstances, if used incorrectly, CTS less-lethal products may cause damage to property, serious bodily injury or death. Therefore, any person using the force option depicted on this page should receive proper training to ensure the safest and most effective use.

PHYSICAL & OPERATIONAL	
Type	Point Control Impact Munitions
Caliber	12 GA
Weapon Compatibility	Cylinder Bore, 18" Barrel Minimum
Cartridge Length	2.40" (61 mm)
Effective Range*	75' (25 M)
Projectile Weight	40 gm
Projectile Material	Shot Filled Ballistic Fiber
Overall Weight	51 gm
Velocity	270-290 ft./sec
Warranty	5 Years from Shipment Date
<p>All specifications are average and are subject to change without notice. All performance specifications are based on testing conducted in Jamestown, PA USA, At an elevation of 1,058 feet above sea level at ambient temperature conditions.</p>	

SHIPPING INFORMATION	
Proper Shipping Name	Cartridges for Weapons Inert Projectile
UN Number	0012
Hazard Class	1.4 S
Labels Required	Explosive 1.4S
Quantity Per Package	5 Cartridges in Cardboard Box
Total Package Weight	50 lb. (400 Cartridges)
Package Type	Fiberboard Box
Package Dimensions	17 x11 x 6
Net Explosive Weight	.23 gm per unit

*The Model 2581 Super-Sock® is in its deployed state immediately upon exiting the barrel. It does not require a minimum range to "unfold" or "stabilize." The Super-Sock® is an aerodynamic projectile. However, accuracy is relative to the shotgun, barrel length, environmental conditions, and the operator. The Super-Sock® is very accurate. However, effectiveness depends on many variable, such as distance, clothing, stature, and the point where the projectile impacts.

CAUTION: Shots to the head, neck, thorax, heart, or spine can result in fatal or serious injury.

MODEL No.	DESCRIPTION:
4551	40MM Multi-3 Foam Baton
	Revision C 10/18

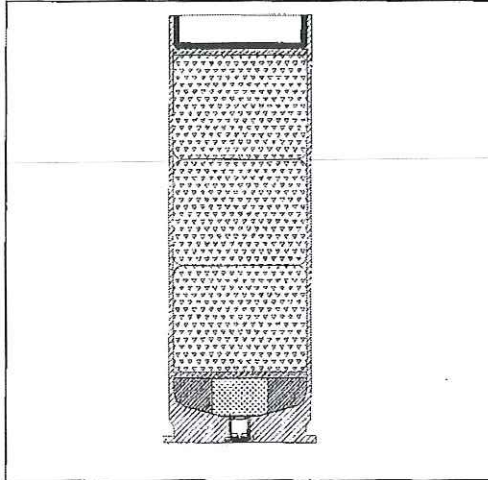

NOT TO SCALE

WARNING: CSI manufactures a variety of CTS less lethal products which are under pressure, pyrotechnic, incendiary, emit projectiles, generate smoke, or are explosive in nature. When used in accordance with CTS training guidelines and the individual agency's policy, they are intended to cause varying degrees of pain and injury, which are temporary. These products are restricted to law enforcement, corrections, and military personnel and are used to gain compliance, disperse crowds, restore order, or temporarily incapacitate dangerous persons. In rare circumstances, if used incorrectly, CTS less-lethal products may cause damage to property, serious bodily injury or death. Therefore, any person using the force option depicted on this page should receive proper training to ensure the safest and most effective use.

PHYSICAL & OPERATIONAL	
Type	Crowd Dispersal Impact Munition
Caliber	40MM
Weapon Compatibility	All 40MM Launchers, M203, M79 and Multi-Launcher Type
Cartridge Length	4.8" (88.9 mm)
Effective Range*	40' (12 M)
Overall Weight	160 gm
Projectile Material	Closed Cell Neoprene
Velocity	300-350 ft./sec
Warranty	5 Years from Shipment Date
<p>All specifications are average and are subject to change without notice. All performance specifications are based on testing conducted in Jamestown, PA USA, At an elevation of 1,058 feet above sea level at ambient temperature conditions.</p>	

SHIPPING INFORMATION	
Proper Shipping Name	Cartridges for Weapons Inert Projectile
UN Number	UN0339
Hazard Class	1.4C
Labels Required	Explosive 1.4C Corrosive
Quantity Per Package	96 Cartridges
Total Package Weight	45 lb.
Package Type	Metal Drum with Lever Lock Lid UN1A2/Y36/S
Package Dimensions	19 x 12 (7 gal. drum) also used for overnight packages
Net Explosive Weight	.42 gm per unit

*The 4551 Foam Baton launches multiple foam batons (3) to affect a general area. The shot pattern of the projectiles will increase over distance. General accuracy and effectiveness is relative to the launcher, barrel length, environmental conditions, the operator, distance, thickness of clothing and the stature of the human target.

Skip firing, aiming the impact munitions toward the ground 3'-10' (1-3 meters) in front of a crowd is an option that should be given strong consideration with these munitions. Skip firing attenuates some of the blunt trauma on the target and reduces the possibility of impacting the human target above the belt line. Do not skip fire on surfaces, such as grass or sand.

CAUTION: Dispersion of the projectiles creates a greater risk of eye injury, and requires the operator to target a low point of impact, below the belt line, on human targets.

MODEL No.	DESCRIPTION:
6210HC	Hexachloroethane (HC) Smoke
	Revision D 10/18

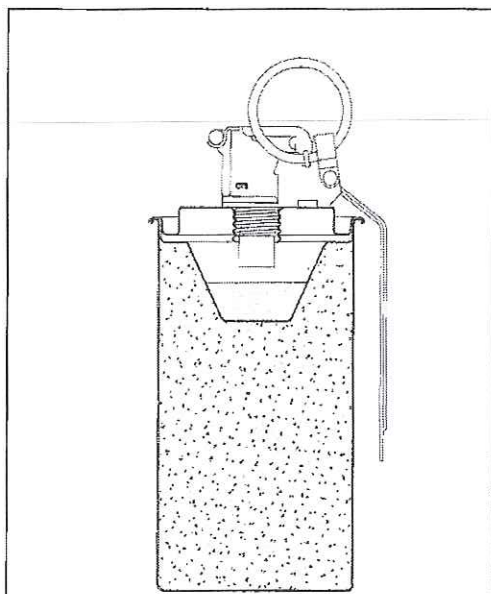

NOT TO SCALE

PHYSICAL & OPERATIONAL	
Type	Irritant & Smoke Pyrotechnic Grenades
Diameter	2.35" (60 mm)
Length	5.5" (140 mm)
Fuze Type	Model 201
Fuze Delay	1.5 +/- 0.3 sec. Average
Launchable	No
Overall Weight	685 gm
Discharge Time	1.5-2.5 Minutes
Emission Ports	4
Warranty	5 Years from Shipment Date
<p>All specifications are average and are subject to change without notice. All performance specifications are based on testing conducted in Jamestown, PA USA, At an elevation of 1,058 feet above sea level at ambient temperature conditions.</p>	

WARNING: CSI manufactures a variety of CTS less lethal products which are under pressure, pyrotechnic, incendiary, emit projectiles, generate smoke, or are explosive in nature. When used in accordance with CTS training guidelines and the individual agency's policy, they are intended to cause varying degrees of pain and injury, which are temporary. These products are restricted to law enforcement, corrections, and military personnel and are used to gain compliance, disperse crowds, restore order, or temporarily incapacitate dangerous persons. In rare circumstances, if used incorrectly, CTS less-lethal products may cause damage to property, serious bodily injury or death. Therefore, any person using the force option depicted on this page should receive proper training to ensure the safest and most effective use.

SHIPPING INFORMATION	
Proper Shipping Name	Ammunition Smoke
UN Number	0303
Hazard Class	1.4G
Labels Required	Explosive 1.4G
Quantity Per Package	28 Grenades
Total Package Weight	32 lb.
Package Type	UN Specification 1A2/Y36/S Metal Drum with Lever Lock Lid
Package Dimensions	19 x 12 (7gal. Drum also used for overnight packages)
Net Explosive Weight	510 gm per unit

CAUTION: Do not use this grenade indoors. The HC formulation produces a very dense smoke from a metallic composition that displaces air and has a high toxicity.



PRODUCT SPECIFICATIONS

MODEL No.	DESCRIPTION:
7290	Flash-Bang Steel Body, Single Use
	Revision D 2/19

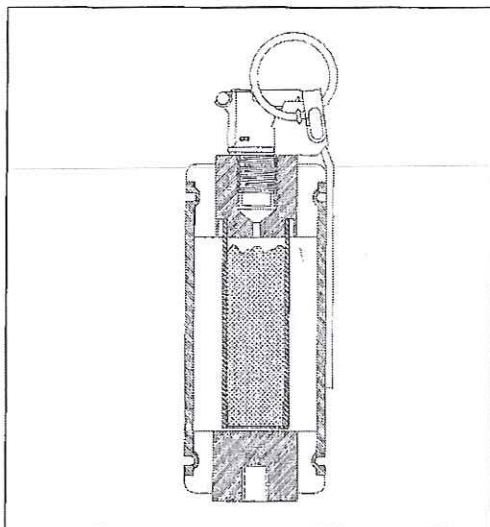

NOT TO SCALE

WARNING: CSI manufactures a variety of CTS less lethal products which are under pressure, pyrotechnic, incendiary, emit projectiles, generate smoke, or are explosive in nature. When used in accordance with CTS training guidelines and the individual agency's policy, they are intended to cause varying degrees of pain and injury, which are temporary. These products are restricted to law enforcement, corrections, and military personnel and are used to gain compliance, disperse crowds, restore order, or temporarily incapacitate dangerous persons. In rare circumstances, if used incorrectly, CTS less-lethal products may cause damage to property, serious bodily injury or death. Therefore, any person using the force option depicted on this page should receive proper training to ensure the safest and most effective use.

PHYSICAL & OPERATIONAL	
Type	Noise-Flash Diversion Device
Material	Steel - Black Chromate
Diameter	2.0" (50.8 mm)
Length	5.85" (148.5 mm)
Weight	665 gm
Blast Ports	10 on top – 10 on bottom
Fuze Delay	1.5 +/- 0.3 sec. Average
Sound Output	165-175 dB Average @ 5 ft
Light Output	2 Million Candela Minimum
Reloadable	Single Use Only
Warranty	5 Years From Shipment Date
<p>All specifications are average and are subject to change without notice. All performance specifications are based on testing conducted in Jamestown, PA USA, At an elevation of 1,058 feet above sea level at ambient temperature conditions.</p>	

SHIPPING INFORMATION	
Proper Shipping Name	Grenade Practice
UN Number	0452
Hazard Class	1.4G
Labels Required	Explosive 1.4G
Quantity Per Package	12
Total Package Weight	27 lb.
Package Type	4G Fiberboard Box double Wall POP
Package Dimensions	13.0" X 9.5" X 8.75" Height
Net Explosive Weight	9 gm per unit

****CAUTION:** The deployment of any non-bursting canister devices onto soft, wet surfaces, such as mud, wet dirt and wet and dry sand may cause blast ports to become blocked, potentially causing the devices to launch and become a hazardous projectile.



CTS is a Division of Combined Systems, Inc.
 388 Kinsman Rd.
 Jamestown, PA 16134 USA
 TEL (724) 932-2177
 FAX (724) 932-2166
 EMAIL Sales@combinedsystems.com
www.combinedsystems.com



PRODUCT SPECIFICATIONS

MODEL No.	DESCRIPTION:
7290M	Flash-Bang, Mini-Bang® Steel Body, Single Use
	Revision D 3/19

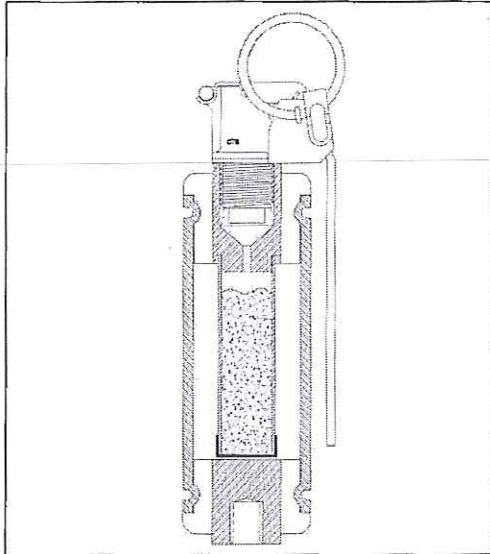

NOT TO SCALE

WARNING: CSI manufactures a variety of CTS less lethal products which are under pressure, pyrotechnic, incendiary, emit projectiles, generate smoke, or are explosive in nature. When used in accordance with CTS training guidelines and the individual agency's policy, they are intended to cause varying degrees of pain and injury, which are temporary. These products are restricted to law enforcement, corrections, and military personnel and are used to gain compliance, disperse crowds, restore order, or temporarily incapacitate dangerous persons. In rare circumstances, if used incorrectly, CTS less-lethal products may cause damage to property, serious bodily injury or death. Therefore, any person using the force option depicted on this page should receive proper training to ensure the safest and most effective use.

PHYSICAL & OPERATIONAL	
Type	Noise-Flash Diversion Device
Body Material	Steel - Black Chromate
Diameter	1.50" (38 mm)
Length	5.40" (137 mm)
Weight	430 gm
Blast Ports	10 on top – 10 on bottom
Fuze Type	Model 201
Fuze Delay	1.5 +/- 0.3 sec. Average
Sound Output	165-175 dB Average
Light Output	2 Million Candela Minimum
Reloadable	Single Use Only
Warranty	5 Years from Shipment Date

All specifications are average and are subject to change without notice.
All performance specifications are based on testing conducted in Jamestown, PA USA,
At an elevation of 1,058 feet above sea level at ambient temperature conditions.

SHIPPING INFORMATION	
Proper Shipping Name	Grenade, Practice
UN Number	0452
Hazard Class	1.4G
Labels Required	Explosive 1.4G
Quantity Per Package	12
Total Package Weight	18 lb.
Package Type	4G Fiberboard Box Double Wall POP
Package Dimensions	12x75" X 9.75" X 9" Height
Net Explosive Weight	8.78 gm per unit

*****CAUTION;** The deployment of any non-bursting canister devices onto soft, wet surfaces, such as mud, wet dirt and wet and dry sand may cause blast ports to become blocked, potentially causing the devices to launch and become a hazardous projectile.



CTS is a Division of Combined Systems, Inc.
 388 Kinsman Rd.
 Jamestown, PA 16134 USA
 TEL (724) 932-2177
 FAX (724) 932-2166
 EMAIL Sales@combinedsystems.com
www.combinedsystems.com



PRODUCT SPECIFICATIONS

MODEL No.	DESCRIPTION:
7290T	Flash-Bang Training Body -- Blue With Left Handed Thread
	Revision C 10/18

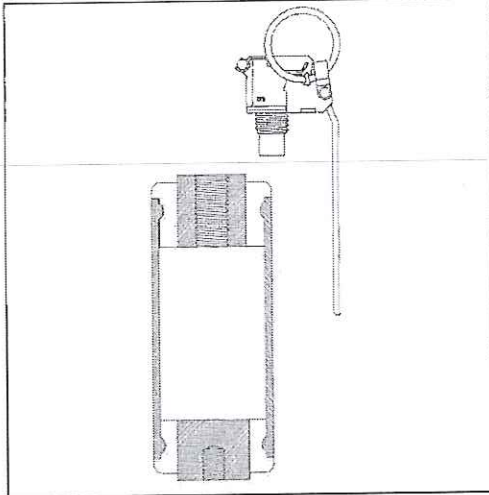

NOT TO SCALE

WARNING: CSI manufactures a variety of CTS less lethal products which are under pressure, pyrotechnic, incendiary, emit projectiles, generate smoke, or are explosive in nature. When used in accordance with CTS training guidelines and the individual agency's policy, they are intended to cause varying degrees of pain and injury, which are temporary. These products are restricted to law enforcement, corrections, and military personnel and are used to gain compliance, disperse crowds, restore order, or temporarily incapacitate dangerous persons. In rare circumstances, if used incorrectly, CTS less-lethal products may cause damage to property, serious bodily injury or death. Therefore, any person using the force option depicted on this page should receive proper training to ensure the safest and most effective use.

PHYSICAL & OPERATIONAL	
Type	Noise-Flash Diversion Device
Material	Steel - Black Chromate/Azure Blue Paint
Diameter	2.0" (50.8 mm)
Length	4.90" (124.4 mm)
Weight	560 gm
Blast Ports	10 on top - 10 on bottom
Fuze Type	Model 201 High-Output
Fuze Delay	1.5 +/- 0.3 sec. Average
Reloadable	Yes
Warranty	5 Years From Shipment Date

All specifications are average and are subject to change without notice.
All performance specifications are based on testing conducted in Jamestown, PA USA,
At an elevation of 1,058 feet above sea level at ambient temperature conditions.

SHIPPING INFORMATION	
Proper Shipping Name	Metal Parts
UN Number	N/A
Hazard Class	1 Piece
Labels Required	N/A
Quantity Per Package	2lbs.
Total Package Weight	N/A
Package Type	Fiberboard Box
Package Dimensions	12" x 9" x 7"
Net Explosive Weight	Non-Hazardous



CTS is a Division of Combined Systems, Inc.

388 Kinsman Rd.
Jamestown, PA 16134 USA
TEL (724) 932-2177
FAX (724) 932-2166

EMAIL Sales@combinedsystems.com
www.combinedsystems.com

PRODUCT SPECIFICATIONS

MODEL No.	DESCRIPTION:
7290MT	Flash-Bang, Mini-Bang® Training Body – Blue With Left Hand Thread
	Revision C 10/18

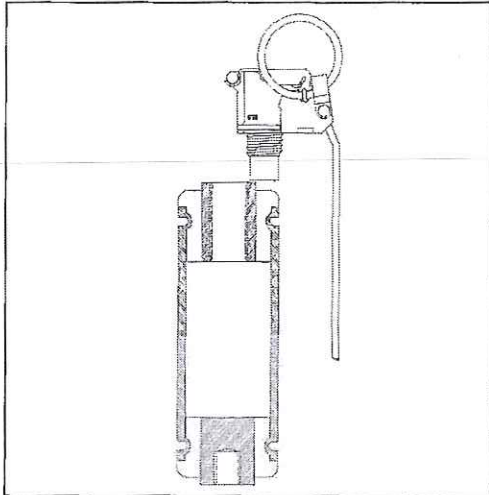

NOT TO SCALE

WARNING: CSI manufactures a variety of CTS less lethal products which are under pressure, pyrotechnic, incendiary, emit projectiles, generate smoke, or are explosive in nature. When used in accordance with CTS training guidelines and the individual agency's policy, they are intended to cause varying degrees of pain and injury, which are temporary. These products are restricted to law enforcement, corrections, and military personnel and are used to gain compliance, disperse crowds, restore order, or temporarily incapacitate dangerous persons. In rare circumstances, if used incorrectly, CTS less-lethal products may cause damage to property, serious bodily injury or death. Therefore, any person using the force option depicted on this page should receive proper training to ensure the safest and most effective use.

PHYSICAL & OPERATIONAL	
Type	Noise-Flash Diversion Device
Material	Steel - Black Chromate/Azure Blue Paint
Diameter	1.50 (38 mm)
Length	4.45" (113 mm)
Weight	320 gm
Blast Ports	10 on top – 10 on bottom
Fuze Type	Model 201 High-Output
Fuze Delay	1.5 +/- 0.3 sec. Average
Reloadable	Yes
Warranty	5 Years from Shipment Date

All specifications are average and are subject to change without notice.
All performance specifications are based on testing conducted in Jamestown, PA USA,
At an elevation of 1,058 feet above sea level at ambient temperature conditions.

SHIPPING INFORMATION	
Proper Shipping Name	Metal Parts
UN Number	N/A
Hazard Class	1 Piece
Labels Required	N/A
Quantity Per Package	1 Piece
Total Package Weight	1lb.
Package Type	Fiberboard Box
Package Dimensions	12" x 10" x 5"
Net Explosive Weight	Non-Hazardous



PRODUCT SPECIFICATIONS

MODEL No.	DESCRIPTION:
9590	No Irritant Sting-Ball Grenade
	Revision C 10/18

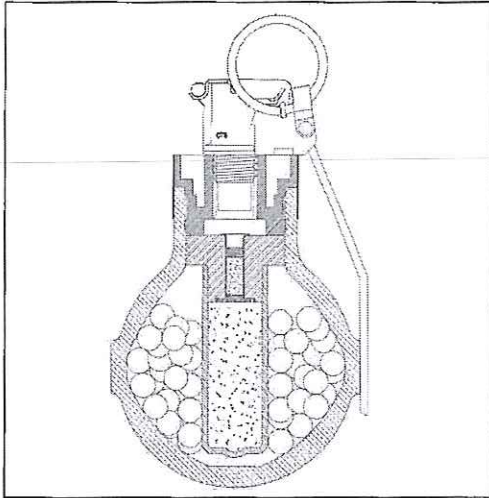

NOT TO SCALE

WARNING: CSI manufactures a variety of CTS less lethal products which are under pressure, pyrotechnic, incendiary, emit projectiles, generate smoke, or are explosive in nature. When used in accordance with CTS training guidelines and the individual agency's policy, they are intended to cause varying degrees of pain and injury, which are temporary. These products are restricted to law enforcement, corrections, and military personnel and are used to gain compliance, disperse crowds, restore order, or temporarily incapacitate dangerous persons. In rare circumstances, if used incorrectly, CTS less-lethal products may cause damage to property, serious bodily injury or death. Therefore, any person using the force option depicted on this page should receive proper training to ensure the safest and most effective use.

PHYSICAL & OPERATIONAL	
Type	Sting-Ball
Material	Rubber
Diameter	3.125" (80 mm)
Length	5.10" (129.5 mm)
Weight	315 gm
Fuze Type	Model 201
Detonation Delay	2.6 ± 1.1- 1.5 Sec.
Payload Material	.31 Caliber Rubber Pellets
Launchable	Yes
Warranty	5 Years From Shipment Date
<p>All specifications are average and are subject to change without notice. All performance specifications are based on testing conducted in Jamestown, PA USA, At an elevation of 1,058 feet above sea level at ambient temperature conditions.</p>	

SHIPPING INFORMATION	
Proper Shipping Name	Grenade, Practice
UN Number	0452
Hazard Class	1.4G
Labels Required	Explosive
Quantity Per Package	12 Grenades
Total Package Weight	18 lb.
Package Type	4G Fiber Board Box Double Wall POP
Package Dimensions	12.75" X16.75" X 7.25" Height
Net Explosive Weight	9.86 gm per unit



CTS is a Division of Combined Systems, Inc.

388 Kinsman Rd.
 Jamestown, PA 16134 USA
 TEL (724) 932-2177
 FAX (724) 932-2166

EMAIL Sales@combinedsystems.com
www.combinedsystems.com

MODEL No.	DESCRIPTION:
9592	Irritant Sting-Ball Grenade w/ CN
9593	Irritant Sting-Ball Grenade w/ CS
9594	Irritant Sting-Ball Grenade w/ OC
	Revision C 10/18

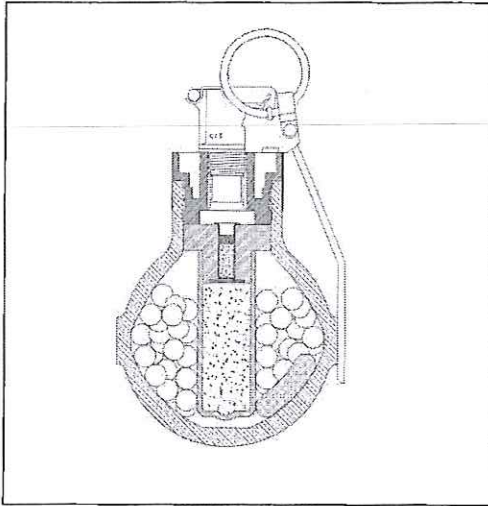

NOT TO SCALE

WARNING: CSI manufactures a variety of CTS less lethal products which are under pressure, pyrotechnic, incendiary, emit projectiles, generate smoke, or are explosive in nature. When used in accordance with CTS training guidelines and the individual agency's policy, they are intended to cause varying degrees of pain and injury, which are temporary. These products are restricted to law enforcement, corrections, and military personnel and are used to gain compliance, disperse crowds, restore order, or temporarily incapacitate dangerous persons. In rare circumstances, if used incorrectly, CTS less-lethal products may cause damage to property, serious bodily injury or death. Therefore, any person using the force option depicted on this page should receive proper training to ensure the safest and most effective use.

PHYSICAL & OPERATIONAL	
Type	Sting-Ball Grenades
Material	Rubber
Diameter	3.125" (80 mm)
Length	5.10" (129.5 mm)
Weight	315 gm
Fuze Type	Model 201
Detonation Delay	2.6 ± 1.1- 1.5 Sec.
Payload Material	.31 Caliber Rubber Pellets & Powder
	CN 10 gms
	CS 9 gms
	OC 9 gms
Launchable	Yes
Warranty	5 Years From Shipment Date
<p>All specifications are average and are subject to change without notice. All performance specifications are based on testing conducted in Jamestown, PA USA, At an elevation of 1,058 feet above sea level at ambient temperature conditions.</p>	

SHIPPING INFORMATION	
Proper Shipping Name	Grenade, Practice
UN Number	0452
Hazard Class	1.4G
Labels Required	Explosive
Quantity Per Package	12 Grenades
Total Package Weight	18 lb.
Package Type	4G Fiber Board Box Double Wall POP
Package Dimensions	12.75" X16.75" X 7.25" Height
Net Explosive Weight	9.86 gm per unit

The 95 Series Sting-Ball Grenades with irritant produce a loud blast, emit bright light, eject rubber pellets and disperse a powder cloud of irritant or inert powder. The primary application of this device is for riot control.

MODEL No.	DESCRIPTION:
3320	37MM CN Liquid Barricade, Smokeless
3330	37MM CS Liquid Barricade, Smokeless
3340	37MM OC Liquid Barricade, Smokeless
Revision C 9/18	

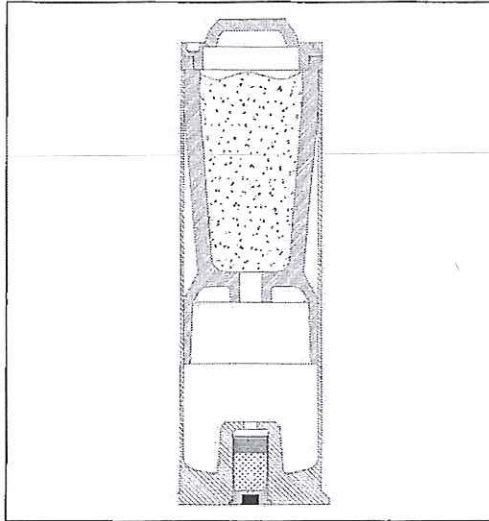

NOT TO SCALE

WARNING: CSI manufactures a variety of CTS less lethal products which are under pressure, pyrotechnic, incendiary, emit projectiles, generate smoke, or are explosive in nature. When used in accordance with CTS training guidelines and the individual agency's policy, they are intended to cause varying degrees of pain and injury, which are temporary. These products are restricted to law enforcement, corrections, and military personnel and are used to gain compliance, disperse crowds, restore order, or temporarily incapacitate dangerous persons. In rare circumstances, if used incorrectly, CTS less-lethal products may cause damage to property, serious bodily injury or death. Therefore, any person using the force option depicted on this page should receive proper training to ensure the safest and most effective use.

PHYSICAL & OPERATIONAL	
Type	Barricade Penetrating Munitions
Caliber	37MM
Weapon Compatibility	37MM 1.5" Riot Guns / M79 Type Grenade Launcher
Cartridge Length	5.45" (138.4 mm)
Effective Range*	50 Yards (45 M)
Muzzle Velocity	385 – 425 ft./sec
Discharge Time	Instantaneous
Warranty	5 Years from Shipment Date
<p>All specifications are average and are subject to change without notice. All performance specifications are based on testing conducted in Jamestown, PA USA, At an elevation of 1,058 feet above sea level at ambient temperature conditions.</p>	

SHIPPING INFORMATION	
Proper Shipping Name	Ammunition Smoke
UN Number	0303
Hazard Class	1.4G
Labels Required	Explosive 1.4G
Quantity Per Package	64
Total Package Weight	36 lb.
Package Type	1A2 Steel Drum
Package Dimensions	19"X12"
Net Explosive Weight	.418 gm per unit

*Effectiveness is dependent upon the type of weapon, angle of impact, environmental conditions, and the type of the intermediate barrier. The greatest probability for penetration occurs when the projectile impacts 90° perpendicular to the intermediate barrier. General usage in tactical situations involves intermediate barriers, such as single pane exterior windows, vehicle windows, pressed wood particle doors, 1-2 layers of wallboard, and interior hollow core doors.

CAUTION: These less-lethal munitions are designed for specific tactical situations. One must be trained specifically in the deployment of barricade penetrating munitions and exercise extreme care and caution to minimize the possibility of this projectile striking a human opposite the barrier.

MODEL No.	DESCRIPTION:
3421	37MM CN Powder Barricade, Smokeless
3431	37MM CS Powder Barricade, Smokeless
3441	37MM OC Powder Barricade, Smokeless
	Revision C 9/18

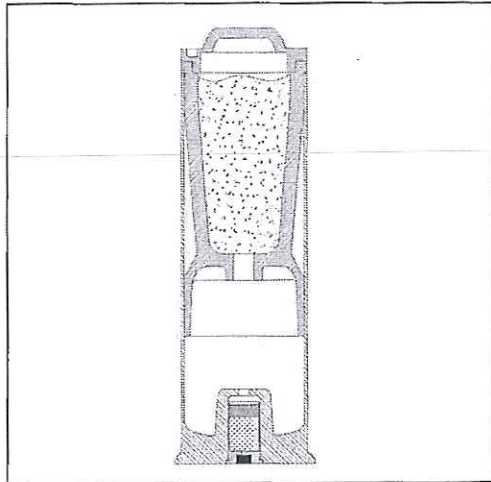

NOT TO SCALE

WARNING: CSI manufactures a variety of CTS less lethal products which are under pressure, pyrotechnic, incendiary, emit projectiles, generate smoke, or are explosive in nature. When used in accordance with CTS training guidelines and the individual agency's policy, they are intended to cause varying degrees of pain and injury, which are temporary. These products are restricted to law enforcement, corrections, and military personnel and are used to gain compliance, disperse crowds, restore order, or temporarily incapacitate dangerous persons. In rare circumstances, if used incorrectly, CTS less-lethal products may cause damage to property, serious bodily injury or death. Therefore, any person using the force option depicted on this page should receive proper training to ensure the safest and most effective use.

PHYSICAL & OPERATIONAL

Type	Barricade Penetrating Munitions
Caliber	37MM
Weapon Compatibility	37MM 1.5" Riot Guns / M79 Type Grenade Launcher
Cartridge Length	5.45" (138.4 mm)
Effective Range*	50 Yards (45 M)
Muzzle Velocity	385 – 425 ft./sec
Discharge Time	Instantaneous
Warranty	5 Years from Shipment Date

All specifications are average and are subject to change without notice. All performance specifications are based on testing conducted in Jamestown, PA USA, At an elevation of 1,058 feet above sea level at ambient temperature conditions.

SHIPPING INFORMATION

Proper Shipping Name	Ammunition Smoke
UN Number	0303
Hazard Class	1.4G
Labels Required	1.4 Explosive
Quantity Per Package	64
Total Package Weight	39 lb
Package Type	1A2 Steel Drum
Package Dimensions	19 x 12 (7 gal. drum) Also used for Overnight Packages
Net Explosive Weight	.418gm per unit

*Effectiveness is dependent upon the type of weapon, angle of impact, environmental conditions, and the type of the intermediate barrier. The greatest probability for penetration occurs when the projectile impacts 90° perpendicular to the intermediate barrier. General usage in tactical situations involves intermediate barriers, such as single pane exterior windows, vehicle windows, pressed wood particle doors, 1-2 layers of wallboard, and interior hollow core doors.

CAUTION: These less-lethal munitions are designed for specific tactical situations. One must be trained specifically in the deployment of barricade penetrating munitions and exercise extreme care and caution to minimize the possibility of this projectile striking a human opposite the barrier.

MODEL No.	DESCRIPTION:
4210	40MM White Smoke
4220	40MM CN Smoke
4230	40MM CS Smoke
Revision C 9/18	

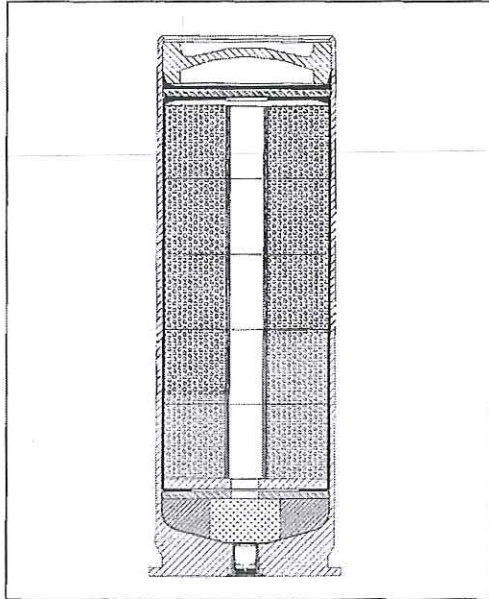

NOT TO SCALE

WARNING: CSI manufactures a variety of CTS less lethal products which are under pressure, pyrotechnic, incendiary, emit projectiles, generate smoke, or are explosive in nature. When used in accordance with CTS training guidelines and the individual agency's policy, they are intended to cause varying degrees of pain and injury, which are temporary. These products are restricted to law enforcement, corrections, and military personnel and are used to gain compliance, disperse crowds, restore order, or temporarily incapacitate dangerous persons. In rare circumstances, if used incorrectly, CTS less-lethal products may cause damage to property, serious bodily injury or death. Therefore, any person using the force option depicted on this page should receive proper training to ensure the safest and most effective use.

PHYSICAL & OPERATIONAL	
Type	Irritant & Smoke Pyrotechnic Projectiles
Caliber	40MM
Weapon Compatibility	All 40MM Launchers, M203, M79 and Multi-Launcher Type
Cartridge Length	4.8" (122 mm)
Effective Range*	110 yards (100 m)
Overall Weight	200 gm
Discharge Time	20-40 Seconds
Warranty	5 Years from Shipment Date
<p>All specifications are average and are subject to change without notice. All performance specifications are based on testing conducted in Jamestown, PA USA, At an elevation of 1,058 feet above sea level at ambient temperature conditions.</p>	

SHIPPING INFORMATION	
Proper Shipping Name	Ammunition Smoke
UN Number	0303
Hazard Class	1.4G
Labels Required	Explosive 1.4G
Quantity Per Package	96 Cartridges
Total Package Weight	53 lb.
Package Type	UN Specification 1A2/Y36/S Metal Drum with Lever Lock Lid
Package Dimensions	19 x 12 (7 gal. drum, also used for overnight packages)
Net Explosive Weight	87.40gm per unit

*Effective range is dependent upon environmental factors, especially wind.

MODEL No.	DESCRIPTION:
5400	Smoke Flameless Expulsion Canister Grenade
5420	CN Flameless Expulsion Canister Grenade
5430	CS Flameless Expulsion Canister Grenade
5440	OC Flameless Expulsion Canister Grenade

Revision E 10/18

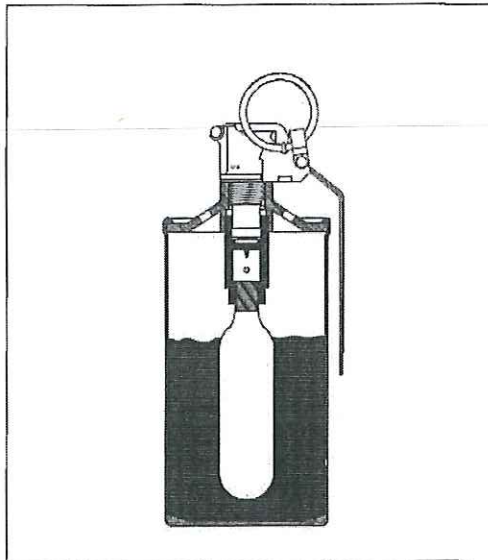

NOT TO SCALE

WARNING: CSI manufactures a variety of CTS less lethal products which are under pressure, pyrotechnic, incendiary, emit projectiles, generate smoke, or are explosive in nature. When used in accordance with CTS training guidelines and the individual agency's policy, they are intended to cause varying degrees of pain and injury, which are temporary. These products are restricted to law enforcement, corrections, and military personnel and are used to gain compliance, disperse crowds, restore order, or temporarily incapacitate dangerous persons. In rare circumstances, if used incorrectly, CTS less-lethal products may cause damage to property, serious bodily injury or death. Therefore, any person using the force option depicted on this page should receive proper training to ensure the safest and most effective use.

PHYSICAL & OPERATIONAL

Type	Irritant Non-Pyrotechnic Grenade
Diameter	2.60" (66 mm)
Length	6.20" (157 mm)
Fuze Type	Model 201
Fuze Delay	1.5 +/- 0.3 sec. Average
Launchable	Yes
Overall Weight	335 gm
Discharge Time	Instantaneous
Emission Ports	2
Warranty	5 Years From Date of Manufacture

All specifications are average and are subject to change without notice.

All performance specifications are based on testing conducted in Jamestown, PA USA, At an elevation of 1,058 feet above sea level at ambient temperature condition

SHIPPING INFORMATION

Proper Shipping Name	Ammunition, Tear Producing
UN Number	Model 5400 - 0303 Models 5420,5430,5440 - 0301
Hazard Class	1.4 G (6.1,8)
Labels Required	1.4 G
Quantity Per Package	24
Total Package Weight	26 lbs.
Package Type	UN Specification 1A2/Y36/S Metal Drum with Lever Lock Lid
Package Dimensions	19 x12 (7 gal. drum) Also used for overnight Packages
Net Explosive Weight	0.9 gm per unit

CAUTION: The 5400 Series Grenade expels its powder payload rapidly and may produce sudden erratic movement of the device.

MODEL No.	DESCRIPTION:
5210	White Smoke Canister Grenade
5220	CN Canister Grenade
5230	CS Canister Grenade
	Revision C 10/18

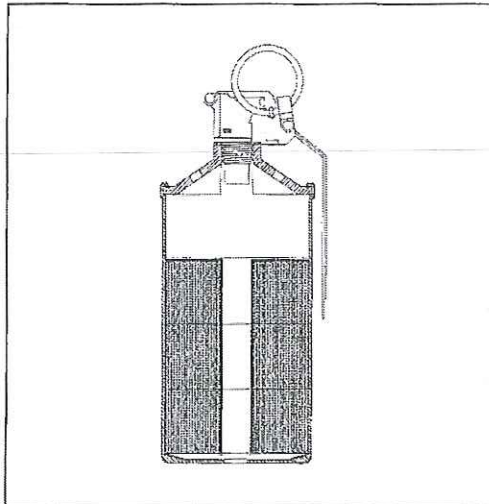

NOT TO SCALE

WARNING: CSI manufactures a variety of CTS less lethal products which are under pressure, pyrotechnic, incendiary, emit projectiles, generate smoke, or are explosive in nature. When used in accordance with CTS training guidelines and the individual agency's policy, they are intended to cause varying degrees of pain and injury, which are temporary. These products are restricted to law enforcement, corrections, and military personnel and are used to gain compliance, disperse crowds, restore order, or temporarily incapacitate dangerous persons. In rare circumstances, if used incorrectly, CTS less-lethal products may cause damage to property, serious bodily injury or death. Therefore, any person using the force option depicted on this page should receive proper training to ensure the safest and most effective use.

PHYSICAL & OPERATIONAL

Type	Irritant & Smoke Pyrotechnic Grenades
Diameter	2.60" (66 mm)
Length	6.20" (157 mm)
Fuze Type	Model 201
Fuze Delay	1.5 +/- 0.3 sec. Average
Launchable	Yes
Overall Weight	460 gm
Discharge Time	20 - 40 Seconds
Emission Ports	5
Warranty	5 Years From Shipment Date

All specifications are average and are subject to change without notice.
All performance specifications are based on testing conducted in Jamestown, PA USA,
At an elevation of 1,058 feet above sea level at ambient temperature conditions.

SHIPPING INFORMATION

Proper Shipping Name	Ammunition, Smoke
UN Number	0303
Hazard Class	1.4G
Labels Required	Explosive 1.4G
Quantity Per Package	24 Grenades
Total Package Weight	33 lb.
Package Type	UN Specification 1A2/Y36/S Metal Drum with Lever Lock Lid
Package Dimensions	19x12 (7 gal. drum also used for overnight packages)
Net Explosive Weight	222 gm per unit



ELITE PERFORMANCE AMMUNITION
50 FMJ Cartridges Total Cartridges

ELITE PERFORMANCE AMMUNITION
SIG FMJ
115 gr. FMJ
259 ft./sec.

SIG SAUER®
when it counts®
9mm LUGER | 115 gr. FMJ
M21 1185 ft./sec
259 ft./sec

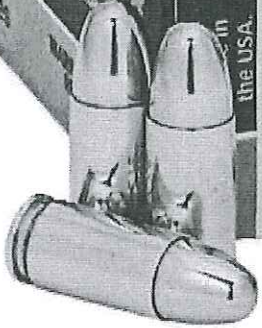

9MM, 115GR, ELITE BALL, FMJ

SPECS

AMMO TYPE
FMJ
CALIBER
9mm Luger
GRAIN WEIGHT
115 gr
MUZZLE VELOCITY
1185 fps
MUZZLE ENERGY
359 ft-lb
QTY PER PACKAGE
50
MSRP
\$16.95

DETAILS

Engineered to match SIG V-Crown[®] ballistics for a more seamless transition from practice to carry ammunition, SIG FMJ delivers round after round of affordable, premium-level performance. Featuring dependable primers and the same exceptional, clean-burning propellants used in breakthrough SIG V-Crown[®] defense rounds, SIG FMJ durable copper-jacketed bullets remain intact on impact with equivalent point-of-impact, recoil and energy. Practice or competition, SIG FMJ measures up.

ATTENTION:

- You must be 18 or older to purchase rifle ammunition and 21 or older to purchase handgun ammunition.
- For safety reasons, we do not accept returns of ammunition.
- All ammunition will be shipped via ground delivery.
- Adult signature required on delivery.
- Please ensure you are purchasing and using the correct type of ammunition for your firearm.
- Check the local laws of your area for any other laws or regulations before ordering.

COLUMBUS CONSOLIDATED GOVERNMENT ANNUAL CONTRACT ROUTING MEMORANDUM

DATE: August 19, 2020

SUBJECT: Ammunition (Annual Contract); RFB No. 20-0062

FROM: Patti Postorino, Purchasing Division

Please route for appropriate signatures the one (1) copy of each of the four attached contracts with Dana Safety Supply Inc (Greensboro, NC), Gulf States Distributors Inc (Montgomery, AL), Precision Delta Corporation (Ruleville, MS), and Smyrna Police Distributors Inc (Smyrna, GA) for the estimated annual contract value of \$191,077.40. These firms will provide ammunition and munitions of various types and quantities on an "as needed" basis to Columbus Consolidated Government (the City) to be utilized by the Public Safety Departments.

The term of this contract shall be for two (2) years with the option to renew for three (3) additional twelve-month periods. Contract renewal is contingent upon the mutual agreement of the City and the Contractor.

Funds are budgeted each fiscal year for this on-going expense:

Public Safety Departments: General Fund - Police, Marshal, Muscogee County Prison, and Sheriff - Operating Materials; 0101-400-2900-CTRN-6728, 0101-400-2200-STAF-6728, 0101-530-3000-MRSH-6728, 0101-420-1000-MCCI-6728, 0101-550-1000-SHRF-6728, 0101-550-2300-STRN-6728, 0101-550-2600-JAIL-6728, 0101-550-2100-SPTL-6728.

Council authorized this contract per Resolution No. 223-20, dated August 11, 2020 (copy is attached).

Signatories	Signatures Required (<i>No initials please</i>)	Date
Purchasing Division Manager Signature of Approval		8/19/20
City Attorney: Signature required on Contracts	Form Approved: C.C.F., City Attorney	8/19/20
City Manager: Signature required on Contracts		8/25/2020
Clerk of Council: Signature Required on Contracts & Attest/Seal		8/24/2020
Buyer: Process / Distribute		08/28/2020

After all signatures have been applied, please contact Purchasing Division (ext - 3070) for distribution.

RESOLUTION

NO. 223-20

A RESOLUTION AUTHORIZING THE PURCHASE OF AMMUNITION AND MUNITIONS FROM DANA SAFETY SUPPLY, INC. (GREENSBORO, NC), GULF STATES DISTRIBUTORS, INC. (MONTGOMERY, AL), PRECISION DELTA CORPORATION (RULEVILLE, MS), AND SMYRNA POLICE DISTRIBUTORS, INC. (SMYRNA, GA), ON AN "AS NEEDED" BASIS, FOR THE ESTIMATED ANNUAL CONTRACT VALUE OF \$191,077.40.

WHEREAS, The various types of ammunition include: duty ammunition, practice ammunition, and shotgun ammunition. The munitions supplies include: smoke canisters, tactical grenades, stinger rubber ball grenades, etc. The ammunition and munitions will be used by Columbus Public Safety Departments (Police, Marshal, Muscogee County Prison and Sheriff) and will be purchased on an "as needed" basis; and,

WHEREAS, the initial contract period shall be for two years, with the option to renew for three additional twelve-month periods. Contract renewals will be contingent upon the mutual agreement of the City and the Contractor.

NOW, THEREFORE, THE COUNCIL OF COLUMBUS, GEORGIA, HEREBY RESOLVES AS FOLLOWS:

That the City Manager is hereby authorized to purchase ammunition and munitions from Dana Safety Supply, Inc. (Greensboro, NC), Gulf States Distributors, Inc. (Montgomery, AL), Precision Delta Corporation (Ruleville, MS) and Smyrna Police Distributors, Inc. (Smyrna, GA) on an "as needed" basis, for the estimated annual contract value of \$191,077.40. Funds are budgeted each fiscal year for this on-going expense: General Fund - Police, Marshal, Muscogee County Prison, and Sheriff - Operating Materials; 0101-400-2900-CTRN-6728, 0101-400-2200-STAF-6728, 0101-530-3000-MRSH-6728, 0101-420-1000-MCCI-6728, 0101-550-1000-SHRF-6728; 0101-550-2300-STRN-6728; 0101-550-2600-JAIL-6728, 0101-550-2100-SPTL-6728.

Introduced at a regular meeting of the Council of Columbus, Georgia, held the 11th day of August 2020 and adopted at said meeting by the affirmative vote of eight members of said Council.

Councilor Allen	voting	<u>YES</u>
Councilor Barnes	voting	<u>ABSENT FOR VOTE</u>
Councilor Crabb	voting	<u>YES</u>
Councilor Davis	voting	<u>YES</u>
Councilor Garrett	voting	<u>YES</u>

Councilor House voting YES
Councilor Huff voting YES
Councilor Thomas voting YES
Councilor Thompson voting YES
Councilor Woodson voting ABSENT

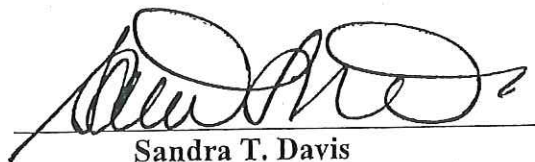

Sandra T. Davis
Clerk of Council



B. H. "Skip" Henderson, III
Mayor

CONTRACT

THIS CONTRACT, executed this 25th day of August 2020, by and between the **Consolidated Government of Columbus, Georgia**, hereinafter called the "City", and **Gulf States Distributors, Inc. (Montgomery, AL)**, hereinafter called the "Contractor".

WITNESSETH:

That in consideration of the mutual covenants, obligations, and terms set-forth in the attached proposal and specifications, the parties hereby agree as follows:

1. That the Contractor met all proposal requirements and was evaluated most responsive for providing **Ammunition for Public Safety Departments (Annual Contract)**, per **RFB No. 20-0062**, and was awarded the Contract by Columbus City Council on Tuesday, August 11, 2020, Resolution No. 223-20, for the contract term of two years, beginning October 1, 2020 through September 30, 2022, for furnishing the same in accordance with the specifications prepared by the City and the proposal of the Contractor.

2. The Contractor will, at its own cost and expense, furnish all tools, materials and labor required to be furnished, provide all related services required, and meet all other requirements or conditions imposed, all strictly in accordance with the City's Business Requirements, the City's Request for Bids, dated May 20, 2020 (and all addenda thereto), the Contractor's bid dated June 17, 2020 and the awarded items which are attached hereto as exhibits "A", "B" and "C" respectively, and which are by reference made a part hereof to the same extent as if fully set out herein.

3. On the faithful performance of this Contract by the Contractor, the City will pay the Contractor in accordance with the terms and on the conditions stated in this Contract and the exhibits attached to and by reference made a part hereof.

FORM 3

CONTRACT SIGNATURE PAGE

AMMUNITION FOR PUBLIC SAFETY DEPARTMENTS
(ANNUAL CONTRACT)
RFB No. 20-0062

THE UNDERSIGNED HEREBY DECLARES THAT HE HAS/THEY HAVE CAREFULLY EXAMINED THE SPECIFICATIONS HEREIN REFERRED TO AND WILL PROVIDE ALL EQUIPMENT, TERMS AND SERVICES TO THE CONSOLIDATED GOVERNMENT OF COLUMBUS, GEORGIA.

Crawley Trammell
Witness as to the signing of the contract

Blanie Trammell
Witness as to the signing of the contract

(Corporate seal, if applicable)

[Signature] 6-10-20
Signature of Authorized Representative Date

Tommy Trammell Vice President
Print Name and Title of Signatory

Gulf States Distributors Inc.
Company Name

Company Ordering Address

6000 East Shirley Lane
Montgomery AL 36117
Contact Blanie Trammell
Email blanie@gulfstatesdist.com
Telephone 800-223-7869
Fax 334-279-9267

Company Payment Address

P.O. Box 241387
Montgomery, AL 36124-1387
Contact Sharon Parks
Email sharon@gulfstatesdist.com
Telephone 700-223-7869
Fax 334-279-9267

CONSOLIDATED GOVERNMENT OF COLUMBUS, GEORGIA

Accepted this 26th day of August 2020

[Signature]
Asaiah Hugley, City Manager

APPROVED AS TO LEGAL FORM:

[Signature]
Clifton C. Fay, City Attorney

ATTEST:

[Signature]
Sandra T. Davis, Clerk of Council

EXECUTION AUTHORIZED

By Resolution No. 223-20

[Signature]
Clerk of Council

<u>VENDOR / ITEMS</u>	<u>EST QTY</u>	<u>UNIT PRICE</u>	<u>TOTAL COST</u>
Gulf States Distributors, Inc. (Montgomery, AL)			
12 Gauge - Federal - 00 Buck Shot - Reduced Recoil, 9 pellet	25,000	0.4798	\$11,995.00
223 - Hornady - 55gr - TAP	15,000	0.61625	\$9,243.75
45 ACP - Federal - 230gr - Ball - Standard Velocity	10,000	0.279	\$2,790.00
308 - Hornady - 168gr - Match	2,000	0.9775	\$1,955.00
9mm - Federal - 124gr - Reload - FMJ	20,000	0.185	\$3,700.00
223 - Federal - 55BT - Gold Match Boat Tail, Hollow Point	3,000	0.738	\$2,214.00
9mm - Federal Tactical - 147gr - HST HP (P9HST2), New, Bonded	3,000	0.289	\$867.00
9mm - Federal - 147gr - JHP 850 FPR + P Ball	4,500	0.195	\$877.50
12 GA Diversionary Aerial Round	100	7.50	\$750.00
Rubber Ball, w/ White Smoke	100	31.00	\$3,100.00
Canister, Smoke, Pocket	130	21.00	\$2,730.00
Canister, OC	80	46.00	\$3,680.00
VENDOR TOTAL ESTIMATED ANNUAL CONTRACT VALUE			\$ 43,902.25

EXHIBIT A

Columbus Consolidated Government

Ammunition for Public Safety Departments (Annual Contract)

RFB No. 20-0062

Business Requirements

Request for Taxpayer Identification Number and Certification

Give Form to the
 requester. Do not
 send to the IRS.

▶ Go to www.irs.gov/FormW9 for instructions and the latest information.

1 Name (as shown on your income tax return). Name is required on this line; do not leave this line blank.
Gulf States Distributors, Inc.

2 Business name/disregarded entity name, if different from above

3 Check appropriate box for federal tax classification of the person whose name is entered on line 1. Check only one of the following seven boxes.

Individual/sole proprietor or single-member LLC
 C Corporation
 S Corporation
 Partnership
 Trust/estate
 Limited liability company. Enter the tax classification (C=C corporation, S=S corporation, P=Partnership) ▶ _____
 Note: Check the appropriate box in the line above for the tax classification of the single-member owner. Do not check LLC if the LLC is classified as a single-member LLC that is disregarded from the owner unless the owner of the LLC is another LLC that is not disregarded from the owner for U.S. federal tax purposes. Otherwise, a single-member LLC that is disregarded from the owner should check the appropriate box for the tax classification of its owner.
 Other (see instructions) ▶ _____

4 Exemptions (codes apply only to certain entities, not individuals; see instructions on page 3):
 Exempt payee code (if any) _____
 Exemption from FATCA reporting code (if any) _____
(Applies to accounts maintained outside the U.S.)

5 Address (number, street, and apt. or suite no.) See instructions.
6000 East Shirley Lane

6 City, state, and ZIP code
Montgomery, AL 36117

7 List account number(s) here (optional)

Requester's name and address (optional)

Print or type.
 See Specific Instructions on page 3.

Part I Taxpayer Identification Number (TIN)

Enter your TIN in the appropriate box. The TIN provided must match the name given on line 1 to avoid backup withholding. For individuals, this is generally your social security number (SSN). However, for a resident alien, sole proprietor, or disregarded entity, see the instructions for Part I, later. For other entities, it is your employer identification number (EIN). If you do not have a number, see *How to get a TIN*, later.

Note: If the account is in more than one name, see the instructions for line 1. Also see *What Name and Number To Give the Requester* for guidelines on whose number to enter.

Social security number

--	--	--

OR

Employer identification number

--	--	--

Part II Certification

Under penalties of perjury, I certify that:

- The number shown on this form is my correct taxpayer identification number (or I am waiting for a number to be issued to me); and
- I am not subject to backup withholding because: (a) I am exempt from backup withholding, or (b) I have not been notified by the Internal Revenue Service (IRS) that I am subject to backup withholding as a result of a failure to report all interest or dividends, or (c) the IRS has notified me that I am no longer subject to backup withholding; and
- I am a U.S. citizen or other U.S. person (defined below); and
- The FATCA code(s) entered on this form (if any) indicating that I am exempt from FATCA reporting is correct.

Certification instructions. You must cross out item 2 above if you have been notified by the IRS that you are currently subject to backup withholding because you have failed to report all interest and dividends on your tax return. For real estate transactions, item 2 does not apply. For mortgage interest paid, acquisition or abandonment of secured property, cancellation of debt, contributions to an individual retirement arrangement (IRA), and generally, payments other than interest and dividends, you are not required to sign the certification, but you must provide your correct TIN. See the instructions for Part II, later.

Sign Here Signature of U.S. person ▶ Date ▶ **1-21-2020**

General Instructions

Section references are to the Internal Revenue Code unless otherwise noted.

Future developments. For the latest information about developments related to Form W-9 and its instructions, such as legislation enacted after they were published, go to www.irs.gov/FormW9.

Purpose of Form

An individual or entity (Form W-9 requester) who is required to file an information return with the IRS must obtain your correct taxpayer identification number (TIN) which may be your social security number (SSN), individual taxpayer identification number (ITIN), adoption taxpayer identification number (ATIN), or employer identification number (EIN), to report on an information return the amount paid to you, or other amount reportable on an information return. Examples of information returns include, but are not limited to, the following.

- Form 1099-INT (interest earned or paid)

- Form 1099-DIV (dividends, including those from stocks or mutual funds)
 - Form 1099-MISC (various types of income, prizes, awards, or gross proceeds)
 - Form 1099-B (stock or mutual fund sales and certain other transactions by brokers)
 - Form 1099-S (proceeds from real estate transactions)
 - Form 1099-K (merchant card and third party network transactions)
 - Form 1098 (home mortgage interest), 1098-E (student loan interest), 1098-T (tuition)
 - Form 1099-C (canceled debt)
 - Form 1099-A (acquisition or abandonment of secured property)
- Use Form W-9 only if you are a U.S. person (including a resident alien), to provide your correct TIN.
- If you do not return Form W-9 to the requester with a TIN, you might be subject to backup withholding. See What is backup withholding, later.*

08/18/2020

Search by TIN, Acct., or N

Check for imported payees with non-matching TIN data and verify new payees

TIN Matching allows you to verify your Payee data against the IRS TIN Matching database to verify if you have the cor

Sovos can take care of your mismatched TINs & B-Notices

Sovos offers the ability to automatically mail the appropriate forms to your mismatched payees and request corrected information. The responses come directly to you, and the W-9/B-Notice solicitations are saved for your reference in File Manager. Depending on your subscription, additional fees may apply.

[Print & Mail W-9 Solicitations](#)

[Print & Mail B-Notices](#)

The W9 Solicitation button has been disabled as you have already sent your solicitations.

Mismatched Records

TIN	Name

[Download](#)

Individual TIN Lookup

Verify individual Payee Social Security and Employer ID numbers.

Name:

TIN:

[Verify Payee](#)

TIN Status: PASS

OFAC Check: PASS

DMF Check: PASS

[Back to Home](#)

STATE OF ALABAMA

MONTGOMERY COUNTY

LICENSE NO.
0000717

CONTROL NO.
0320001157

ACCOUNT NO.
001157

ISSUED TO:

GULF STATES DISTRIBUTORS
6000 EAST SHIRLEY LN
MONTGOMERY, AL 36117-1993

LICENSE YEAR
2019-2020

DATE ISSUED		
10	10	2019
MO.	DAY	YR.

LICENSE TYPE	
STORE LICENSE	<input type="checkbox"/>
CHAIN STORE LICENSE	<input type="checkbox"/>
OCCUPATIONAL LICENSE	<input checked="" type="checkbox"/>

BUSINESS LOCATION:
6000 EAST SHIRLEY LN
MONTGOMERY, AL 36117-1993

EXPIRES
September 30, 2020
RENEW IN OCTOBER

SECTION	BUSINESS TYPE	LICENSE AMOUNT	FEE	PENALTY	CITATION	INTEREST	TOTAL
143	PISTOLS, REVOLVERS, BOWIE & DIRK KNIVES, ETC	225.00	1.00	0.00	0.00	0.00	226.00
158	SHOTGUNS, RIFLES , AMMUNITION	37.50	1.00	0.00	0.00	0.00	38.50

<p>TRANSFER OF LICENSE</p> <p>Evidence having been adduced before me that a bona fide sale of the business licensed by this certificate has been made by licensee, this license is transferred to said purchaser.</p>		<p><u>KATHLEEN D. BAXTER</u> State Comptroller</p>	<table border="1"> <tr> <td>TOTAL</td> <td>264.50</td> </tr> <tr> <td>MAIL FEE</td> <td>0.00</td> </tr> <tr> <td>TOTAL WITH MAIL FEE</td> <td>264.50</td> </tr> </table>	TOTAL	264.50	MAIL FEE	0.00	TOTAL WITH MAIL FEE	264.50
TOTAL	264.50								
MAIL FEE	0.00								
TOTAL WITH MAIL FEE	264.50								
<p>Name of Purchaser</p>		<p><u>VERNON BARNETT</u> Commissioner of Revenue</p>							
<p>Issuing Authority</p>		<p><u>STEVEN L. REED</u> Issuing Authority</p>							

L4 10/10/2019 11:43AM CHECK

10/10/2019 11:43AM
GULF STATES DISTRIBUTORS
6000 EAST SHIRLEY LN
MONTGOMERY AL36117-1993
143 - PISTOLS, REVOLVERS, BOWIE & DIRK
KNIVES, ETC 226.00
158 - SHOTGUNS, RIFLES , AMMUNITION
38.50
Total: 264.50

Acct Number 001157

License#: 0000717

THIS
LICENSE
EXPIRES

CITY OF MONTGOMERY
MONTGOMERY, ALABAMA

No. 202001369

December 31st

20



20

PLEASE RENEW
BY FEBRUARY 1ST
OF THE FOLLOWING YEAR

BUSINESS LICENSE

LICENSE VALID
ONLY AT LOCATION
INDICATED.
NOT TRANSFERABLE

MAILING NAME AND ADDRESS

LOCAL TRADE NAME AND PHYSICAL LOCATION

GULF STATES DISTRIBUTORS
P O BOX 241387
MONTGOMERY, AL 36124

GULF STATES DISTRIBUTORS
6000 SHIRLEY LN EAST
MONTGOMERY, AL 36111

THE FIRM, CORPORATION, ORGANIZATION, BUSINESS OR PERSON, WHOSE NAME APPEARS ABOVE HAS PAID THE REQUIRED LICENSE FEE AND IS AUTHORIZED TO ENGAGE IN BUSINESS IN MONTGOMERY, ALABAMA AS INDICATED BELOW.

CODE	ACCOUNT NUMBER	LICENSE NUMBER	RECEIPT NUMBER	TYPE OF LICENSE
421990	5940246	202001369		GUNS WHOLESALE/RETAIL

DATE ISSUED

01/13/2020

MONTGOMERY,
ALABAMA

MUST BE POSTED IN AREA ACCESSIBLE TO PUBLIC

Pamela Barner-McCorvey

Pamela Barner-McCorvey
Revenue Manager

NOTICE
License issued subject
to compliance with all
pertinent city codes.

EXHIBIT C

Columbus Consolidated Government

Ammunition for Public Safety Departments (Annual Contract)

RFB No. 20-0062

Gulf States Distributors, Inc.

Bid Submission

FORM 1

COMMUNICATION CONCERNING THIS SOLICITATION

THIS PAGE MUST BE SIGNED AND RETURNED WITH THE VENDOR'S BID/PROPOSAL. FAILURE TO INCLUDE THIS FORM WILL AUTOMATICALLY RENDER VENDOR'S RESPONSE NON-RESPONSIVE.

.....
ALL QUESTIONS OR CLARIFICATIONS CONCERNING THIS SOLICITATION SHALL BE SUBMITTED IN WRITING. THE CITY WILL NOT ORALLY OR TELEPHONICALLY ADDRESS ANY QUESTION OR CLARIFICATION REGARDING BID/PROPOSAL SPECIFICATIONS. IF A VENDOR VISITS OR CALLS THE PURCHASING DIVISION WITH SUCH QUESTIONS, HE OR SHE WILL BE INSTRUCTED TO SUBMIT THE QUESTIONS IN WRITING.

ALL CONTACT CONCERNING THIS SOLICITATION SHALL BE MADE THROUGH THE PURCHASING DIVISION. BIDDERS SHALL NOT CONTACT CITY EMPLOYEES, DEPARTMENT HEADS, USING AGENCIES, EVALUATION COMMITTEE MEMBERS, INCLUDING NON-CCG EMPLOYEES, CONTRACTED PERSONNEL ASSOCIATED WITH THIS PARTICULAR PROJECT (I.E. ARCHITECTS, ENGINEERS, CONSULTANTS), OR ELECTED OFFICIALS WITH QUESTIONS OR ANY OTHER CONCERNS ABOUT THE SOLICITATION. QUESTIONS, CLARIFICATIONS, OR CONCERNS SHALL BE SUBMITTED TO THE PURCHASING DIVISION IN WRITING. IF IT IS NECESSARY THAT A TECHNICAL QUESTION NEEDS ADDRESSING, THE PURCHASING DIVISION WILL FORWARD SUCH TO THE USING AGENCY, WHO WILL SUBMIT A WRITTEN RESPONSE.

THE PURCHASING DIVISION WILL FORWARD WRITTEN RESPONSES TO THE RESPECTIVE BIDDER. IF IT BECOMES NECESSARY TO REVISE ANY PART OF THIS SOLICITATION, A WRITTEN ADDENDUM WILL BE ISSUED TO ALL BIDDERS.

THE CITY IS NOT BOUND BY ANY ORAL REPRESENTATIONS, CLARIFICATIONS, OR CHANGES MADE TO THE WRITTEN SPECIFICATIONS BY CITY EMPLOYEES, UNLESS SUCH CLARIFICATION OR CHANGE IS PROVIDED TO THE BIDDERS IN A WRITTEN ADDENDUM FROM THE PURCHASING MANAGER.

BIDDERS ARE INSTRUCTED TO USE THE ENCLOSED "QUESTION/CLARIFICATION FORM" TO FAX OR EMAIL QUESTION. QUESTIONS AND REQUESTS FOR CLARIFICATION MUST BE SUBMITTED AT LEAST FIVE (5) BUSINESS DAYS BEFORE THE DUE DATE.

ANY REQUEST/CONCERN/PROTEST, AFTER A SOLICITATION HAS CLOSED AND PENDING AWARD, MUST ALSO BE SUBMITTED IN WRITING TO THE PURCHASING DIVISION.

I agree to forward all communication about this solicitation, in writing, to the Purchasing Division. I understand that communication with other persons, other than the Purchasing Division, will render my Bid/Proposal response non-responsive and I will no longer be considered in the solicitation process.

Vendor Name: Gulf States Distributors Inc.

Print Name of Authorized Agent: Tommy Trammell

Signature of Authorized Agent: 

FORM 2

BID FORM

AMMUNITION FOR PUBLIC SAFETY DEPARTMENTS
(ANNUAL CONTRACT)
RFB No. 20-0062

IMPORTANT INFORMATION:

PLEASE SUBMIT ONE (1) ELECTRONIC BID RESPONSE VIA DEMANDSTAR.

By signing this Bid Form, the authorized representative understands the City reserves the right to request any omitted information, with the exception of the "Communication Concerning This Solicitation" (Form 1), WHICH DOES NOT AFFECT THE SUBMITTED BID PRICE. Bidders shall be notified, in writing, and shall have two (2) days, after notification to submit the omitted information. If the omitted information is not received within two (2) days, the Bidder shall be deemed non-responsive and the Bid Submission will be deemed "incomplete". Use the following checklist to verify the items are included in sealed bid:

- Communication Concerning This Solicitation (Form 1) Bid Form (Form 2)
- Pricing Pages (pages 16-20) Contract Signature Page (Form 3) Production Literature
- Warranty & Shelf Life Info Sample Itemized Invoice Business License 2020 W-9 Rev 2018 (Form 4)

Initial below to acknowledge receipt of the following addenda (if any):

Addendum No. 1 II Addendum No. 2 _____ Addendum No. 3 _____

The undersigned hereby declares that he has/they have carefully examined the specifications herein referred to and will provide all services and terms of the Columbus Consolidated Government.

*All shipping, delivery, and/or freight charges must be included in unit price. Columbus Consolidated Government will pay no additional shipping, delivery and/or freight charges or any other additional fees. Inability to make delivery within specified time will authorize the City to purchase from other sources.

Delivery will be made 30 to 120 day(s) after receipt of purchase order.

 Gulf States Distributors Inc. tommy@gulfstatesdist.com
Vendor Business Name Email Address

 [Signature] Tommy Trammell 6-2-20
Authorized Signature Print Name of Signatory Date

Please circle and initial if Business is {Minority} or {Woman} Owned: _____

If certified as a DBE or WBE, list the certifying agency: _____

Not Minority, Woman or DBE owned (please initial) II

COLUMBUS CONSOLIDATED GOVERNMENT
Georgia's First Consolidated Government



FINANCE DEPARTMENT
PURCHASING DIVISION

100 TENTH STREET, P. O. Box 1340
COLUMBUS, GEORGIA 31902-1340
706-225-4087, Fax 706-225-3033
Bid Line 706-653-4536
www.columbusga.org

June 10, 2020

Addendum No. 1
Ammunition For Public Safety Departments
(Annual Contract)
RFB No. 20-0062

Submissions should include acknowledgement of receipt for all Addenda:

Authorized Initials: II

Firm: Gulf States Distributors Inc.

Vendors are informed that the above subject RFB is hereby modified, corrected, or supplemented as specified, described and set forth in this Addendum:

QUESTIONS / RESPONSES

Question: "Is Section III missing from new format? Section III Police.

Response: The Police Department wishes to receive bids on Section I: Ammunition and Section II: Less Lethal. There is no Section III.

Question: "Police Dept - Section 1, 5th Item 9mm 147gr Sub-Sonic Do they want JHP – USA9JHP2 or FMJ USA9mm1?"

Response: The specifications have been changed to add 9mm Winchester 147gr Sub-Sonic FMJ. See Section 1, Item 5., 9mm 147gr Sub-Sonic.

Question: "Marshal's Office - Section 1 9mm +40 S+W Do they want a "bonded" or "non-bonded"? Section 2 9mm +40 S+W Do they want JHP or FMJ training?"

Response: The specifications have been changed to add "Bonded". See Section 1, Item 3., 9mm and Item 4., .40 Caliber Federal. The specifications have been changed to add JHP/Ball for practice ammunition. See Section 2, Item 1., 9mm and Item 2., .40 Caliber Federal,

Question: "Muscogee County Prison - 223 / 5.56mm What grain weight bullet do they want? 65gr or 55gr? Also, do they want a FMJ?"

Response: The specifications have been changed to add 65gr bullet FMJ, and is now Item 2 in the Section.

Question: "Sheriff's Office - 12 GA Rifle Slug Do they want a Reduced Recoil or Standard Load?"

Response: The specifications have been changed to add Reduced Recoil, and is now Item 5 in the Section.

Pricing Pages have been amended for all of the above items.
You must use the attached revised pricing pages.

Please use attached **"REVISED" PRICING PAGE** for each Public Safety Department. The "Pricing Page" for Police has been revised.

Product literature, warranty and shelf life can be found on the factories' websites listed below.

- 1.) www.hornadyle.com
- 2.) le.vistaoutdoor.com
- 3.) www.combinedsystems.com

Andrea J. McCorvey
Purchasing Division Manager

Please let me know if any additional info is needed.

TT.

Product ETA is 30 to 120 Days. Product delivery may be affected by national emergencies.



“REVISED” PRICING PAGE
AMMUNITION FOR PUBLIC SAFETY DEPARTMENTS
(Annual Contract) RFB NO. 20-0062

POLICE DEPARTMENT

VENDOR COMPANY NAME: <i>bull states Dist.</i>							
Section I: AMMUNITION							
<u>Item</u>	<u>Caliber or Gauge</u>	<u>Name Brand</u>	<u>Bullet Weight</u>	<u>Notes</u>	<u>Estimated Quantity</u>	<u>Unit Price (Per Round)</u>	<u>Total Price</u>
1.	12 Gauge	Federal	00 Buck Shot	Reduced Recoil, 9 Pellet LE132-00	25,000 RDS	\$.4798	\$ 11,995. ⁰⁰
2.	223	Hornady	55gr	TAP 83276	15,000 RDS	\$.61625	\$ 9,243. ⁷⁵
3.	5.56	NATO	55 gr Ball	Reloaded Nwo XM193	75,000 RDS	\$.33	\$ 24,750. ⁰⁰
4.	38SPL	Precision	148gr	Hollow Base Wadcutter	25,000 RDS	\$ No Bid	\$ —
5.	9MM	Winchester	147gr	Sub-Sonic FMJ	20,000 RDS	\$ No Bid	\$ —
6.	45ACP	Federal	230gr	Ball, Standard Velocity AE45A	10,000 RDS	\$.279	\$ 2,790. ⁰⁰
7.	308	Hornady	168gr	Match 80725	2,000 RDS	\$.9775	\$ 1,955. ⁰⁰
8.	9mm	Reload Nwo Federal	124gr	FMJ AE9AP	20,000 RDS	\$.185	\$ 3,700. ⁰⁰
9.	223	Federal 6M223M-500	55 BT 69gr BT	Gold Match Boat Tail, Hollow Point	3,000 RDS	\$.738	\$ 2,214. ⁰⁰
10.	9mm	Hornady 90225	135gr	Luger +P Flexlock Critical Duty	10,000 RDS	\$.4125	\$ 4,125. ⁰⁰
Total Section I							\$ 60,772.⁷⁵

VENDOR COMPANY NAME: <i>bull states Dist.</i>				
Section II: LESS LETHAL				
<u>Item</u>	<u>Description</u>	<u>Estimated Quantity</u>	<u>Unit Price</u>	<u>Total Price</u>
1.	CTS 37mm CS Liquid Barricade Smokeless 3300	10 ea.	\$ 18. ⁰⁰	\$ 180. ⁰⁰
2.	CTS 37mm CS Powder Barricade Smokeless 3431	10 ea.	\$ 22.50	\$ 225. ⁰⁰
3.	CTS 37mm OC Liquid Barricade Smokeless 3340	10 ea.	\$ 20.50	\$ 205. ⁰⁰
4.	CTS Indoor OC Vapor Grenade 6340	5 ea.	\$ 40. ⁰⁰	\$ 200. ⁰⁰
5.	CTS CS Baffled Canister Grenade, Pyro Low Flame Potential 5230-B	5 ea.	\$ 39. ⁰⁰	\$ 195. ⁰⁰
6.	40mm Rotary – OC Muzzle Blast Rounds 4640	200 ea.	\$ 24. ⁰⁰	\$ 4,800. ⁰⁰
7.	40mm Rotary – Long Range CS 4630	100 ea.	\$ 21. ⁰⁰	\$ 2,100. ⁰⁰
8.	12 gauge Defense Technology Corp. Desc. Drag Stabilized Bean Bag	100 ea.	\$ No Bid	\$ —
Total Section II				\$ 7,905.⁰⁰
GRAND TOTAL Police Department (Sections I and II)				\$ 68,677.⁷⁵

"REVISED" PRICING PAGE

AMMUNITION FOR PUBLIC SAFETY DEPARTMENTS
(ANNUAL CONTRACT) RFB NO. 20-0062

MARSHAL'S OFFICE

VENDOR COMPANY NAME: Gulf States Dist.							
Section I: AMMUNITION							
Item	Caliber or Gauge	Name Brand	Bullet Weight	Notes	Estimated Quantity	Unit Price (Per Round)	Total Price
1.	12 Gauge	Remington LE	00 Buck, 8 Pellets	Reduced Recoil, PR12BK8-00	1,500 RDS	\$ No Bid	\$ -
2.	223	Remington	55gr	Remington Premier Accutip (PRA223RD)	4,000 RDS	\$ No Bid	\$ -
3.	9mm	Federal Tactical P9HST2	147gr	HST HP (P9HST2) New, Bonded- Non bonded	3,000 RDS	\$.289	\$ 867.00
4.	.40 Caliber	Federal Tactical Discontinued	165gr	Tactical HP (LE40T3), Bonded	1,000 RDS	\$ No Bid	\$ -
Total Section I							\$ 867.00

Section II: PRACTICE AMMUNITION							
1.	9mm	Federal AE9FP	147gr	JHP 850 FPR + P Ball	4,500 RDS	\$.195	\$ 877.50
2.	.40 Caliber	Federal	165gr	JHP/Ball	500 RDS	\$ No Bid	\$ -
3.	.223 Caliber	Remington- Federal	55gr	Ball AE223 L223R3BPLE	8,000 RDS	\$.33	\$ 2,640.00
Total Section II							\$ 3,517.50

GRAND TOTAL Marshal's Office (Sections I and II)	\$ 4,384.50
---	--------------------

"REVISED" PRICING PAGE

AMMUNITION FOR PUBLIC SAFETY DEPARTMENTS
(ANNUAL CONTRACT) RFB NO. 20-0062

MUSCOGEE COUNTY PRISON (MCP)

VENDOR COMPANY NAME:

Gulf States Dist.

PRACTICE AMMUNITION

<u>Item</u>	<u>Caliber or Gauge</u>	<u>Name Brand</u>	<u>Bullet Weight</u>	<u>Notes</u>	<u>Estimated Quantity</u>	<u>Unit Price (Per Round)</u>	<u>Total Price</u>
1.	9 mill Automatic	Remington <i>Federal</i>	115gr	FMJ <i>AE9DP</i>	67,000 RDS	\$ <i>.185</i>	\$ <i>12,395.00</i>
2.	223 / 556 Rifle	Remington	65gr	FMJ	2,000 RDS	\$ <i>No Bid</i>	\$ <i>—</i>
3.	12 Gauge	Remington	00 Buckshot	Reduced Recoil, 8 Pellet	2,000 RDS	\$ <i>No Bid</i>	\$ <i>—</i>
GRAND TOTAL (MCP)							\$ <i>12,395.00</i>

"REVISED" PRICING PAGE

AMMUNITION FOR PUBLIC SAFETY DEPARTMENTS
(ANNUAL CONTRACT) RFB NO. 20-0062

SHERIFF'S OFFICE

VENDOR COMPANY NAME: <i>Bulf States Dist.</i>							
Section I: AMMUNITION							
Item	Caliber or Gauge	Name Brand	Bullet Weight	Notes	Estimated Quantity	Unit Price (Per Round)	Total Price
1.	.45 ACP	Hornady	220gr +P	FlexLock Critical Duty <i>90925</i>	13,000 RDS	\$ <i>.484</i>	\$ <i>6,292.00</i>
2.	9mm	Hornady	135gr	Critical Duty <i>90225</i>	13,000 RDS	\$ <i>.4125</i>	\$ <i>5,362.50</i>
3.	.223 Cal	Hornady	55gr	TAP - Rifle <i>73276</i>	4,000 RDS	\$ <i>.61625</i>	\$ <i>2,465.00</i>
4.	12 Gauge	Remington	8 Pellet	00 Buckshot Reduced Recoil	1,000 RDS	\$ <i>No Bid</i>	\$ <i>-</i>
5.	12 Gauge	Remington	1 OZ	Rifle Slug Reduced Recoil	1,000 RDS	\$ <i>No Bid</i>	\$ <i>-</i>
6.	.45 ACP	Reload. <i>NEW</i> Federal <i>AE45A</i>	230gr	FMJ or Jacketed Hollow Point	100,000 RDS	\$ <i>.279</i>	\$ <i>27,900.00</i>
7.	9mm	Reload. <i>NEW</i> Federal <i>AE9DP</i>	115gr	FMJ or Jacketed Hollow Point	100,000 RDS	\$ <i>.185</i>	\$ <i>18,500.00</i>
8.	223 Cal	Reload. <i>NEW</i> Federal <i>AE333</i>	55gr	FMJ or Jacketed Hollow Point	32,000 RDS	\$ <i>.33</i>	\$ <i>10,560.00</i>
Total Section I							\$ <i>71,079.50</i>

"REVISED" PRICING PAGE

AMMUNITION FOR PUBLIC SAFETY DEPARTMENTS (ANNUAL CONTRACT) RFB NO. 20-0062

SHERIFF'S OFFICE

VENDOR COMPANY NAME: <u>bulk states Dist.</u>				
Section II: MUNITIONS				
Item	Description	Estimated Quantity	Unit Price	Total Price
<i>"All munitions that have a fuse with a pull ring must be equipped with a pull ring safety clip."</i>				
1.	40mm Safe Smoke; 75 - 150 yards <u>4210</u>	50 ea.	\$ 19.00	\$ 950.00
2.	40mm Speed - Heat CS; 75 - 150 yards <u>4230</u>	70 ea.	\$ 19.25	\$ 1,347.50
3.	12 GA Diversionary Aerial Round <u>2595</u> <small>Must order in 25 pk</small>	100 ea.	\$ 7.50	\$ 750.00
4.	12 GA Rubber Pellet Round <u>2552</u> <small>per 5rd bx</small>	500 ea.	\$ 25.00	\$ 2,500.00
5.	12 GA Super Sock Bean Bag Round <u>2581</u> <small>per 5rd bx</small>	150 ea.	\$ 28.95	\$ 868.50
6.	40mm Multiple Foam Baton, Smokeless 75-150 YD <u>4531</u>	20 ea.	\$ 22.00	\$ 440.00
Total Section II				\$ 6,856.00
Section III: HAND DEPLOYABLE MUNITIONS				
<i>"All munitions that have a fuse with a pull ring must be equipped with a pull ring safety clip."</i>				
1.	Rubber Ball, w/ White Smoke <u>9210</u>	100 ea.	\$ 31.00	\$ 3,100.00
2.	Expulsion Grenade, Flameless <u>5400</u>	25 ea.	\$ 39.95	\$ 998.75
3.	Canister, Smoke <u>5210</u>	80 ea.	\$ 29.00	\$ 2,320.00
4.	Canister, Smoke, HC <u>6210-HC</u>	50 ea.	\$ 35.00	\$ 1,750.00
5.	Canister, Smoke, Pocket <u>7210</u>	130 ea.	\$ 21.00	\$ 2,730.00
6.	Canister, CN	30 ea.	\$ No Bid	\$ -
7.	Canister, OC <u>5440</u> <small>11oz net shipping apply</small>	80 ea.	\$ 46.00	\$ 3,680.00
8.	Tactical Grenade, "Flash Bang" <u>7290</u> <small>order in 12pk</small>	25 ea.	\$ 44.00	\$ 1,100.00
9.	Tactical Grenade, "Flash Bang", Small <u>7290-m</u> <small>order in 12pk</small>	25 ea.	\$ 40.50	\$ 1,012.50
10.	Tactical Grenade, "Flash Bang", Training <u>7290-T</u>	25 ea.	\$ 46.25	\$ 1,156.25
11.	Tactical Grenade, "Flash Bang", Training, Small <u>7290-m</u>	25 ea.	\$ 45.00	\$ 1,125.00
12.	CS Grenades Handheld <u>5230</u>	30 ea.	\$ 30.00	\$ 900.00
13.	Stinger Rubber Ball Grenades <u>9590</u> <small>order in 12pk</small>	20 ea.	\$ 45.50	\$ 910.00
14.	Stinger Rubber Ball Grenades w/ OC <u>9594</u> <small>order in 12pk</small>	20 ea.	\$ 45.50	\$ 910.00
Total Section III				\$ 21,692.50
GRAND TOTAL Sheriff's Office (Sections I, II and III)				\$ 99,628.00

FORM 3

CONTRACT SIGNATURE PAGE

AMMUNITION FOR PUBLIC SAFETY DEPARTMENTS
(ANNUAL CONTRACT)
RFB No. 20-0062

THE UNDERSIGNED HEREBY DECLARES THAT HE HAS/THEY HAVE CAREFULLY EXAMINED THE SPECIFICATIONS HEREIN REFERRED TO AND WILL PROVIDE ALL EQUIPMENT, TERMS AND SERVICES TO THE CONSOLIDATED GOVERNMENT OF COLUMBUS, GEORGIA.

Crawley Trammell
Witness as to the signing of the contract

[Signature] 6-10-20
Signature of Authorized Representative Date

Bianca Trammell
Witness as to the signing of the contract

Tommy Trammell Vice President
Print Name and Title of Signatory

(Corporate seal, if applicable)

Gulf States Distributors Inc.
Company Name

Company Ordering Address

Company Payment Address

6000 East Shirley Lane
Montgomery AL 36117

P.O. Box 241387
Montgomery, AL 36124-1387

Contact Bianca Trammell

Contact Sharon Parks

Email bianca@gulfstatesdist.com

Email sharon@gulfstatesdist.com

Telephone 800-223-7869

Telephone 700-223-7869

Fax 334-279-9267

Fax 334-279-9267

CONSOLIDATED GOVERNMENT OF COLUMBUS, GEORGIA

Accepted this ___ day of _____ 20__

APPROVED AS TO LEGAL FORM:

Isaiah Hugley, City Manager

Clifton C. Fay, City Attorney

ATTEST:

Sandra T. Davis, Clerk of Council

Invoice



Gulf States Distributors
 6000 East Shirley Lane
 P.O. Box 241387 (36124-1387)
 Montgomery, AL 36117
 3342712010

Invoice Number: Sample
 Invoice Date: 6/1/2020

Order Number: 0168526
 Order Date: 4/1/2020
 Salesperson: 0030
 Customer Number: GACOLU

Sold To:
 Consolidated Gov't of Columbus
 P.O. Box 1340
 Accounting Division
 Columbus, GA 31902-1340

Ship To:
 Columbus Police Dept
 510 10th St
 Public Safety Bldg 1st Fl
 Columbus, GA 31901

Customer P.O.	Ship VIA	F.O.B.	Terms			
Sample	0		Net 20 days			
Item Number	Unit	Ordered	Shipped	Back Ordered	Price	Amount
HOR83276 .223 55gr Urban TAP	CASE	20.00	20.00	0.00		00.00
						DropShip: N

Sample



Proudly celebrating 40 years of service to law enforcement and military.
 Be on the lookout for special events and anniversary sales all year long.

15-day money back guarantee (less shipping charges) if not completely satisfied. Call 800.223.7869 for return authorization. Special-ordered products are subject to a 50% restock fee. All warranties are held by the manufacturer.
 Please follow us on Facebook and Instagram to stay connected!

Net Invoice: 0.00
 Less Discount: 0.00
 Freight: 0.00
 Sales Tax: 0.00
Invoice Total: 0.00

COLUMBUS CONSOLIDATED GOVERNMENT ANNUAL CONTRACT ROUTING MEMORANDUM

DATE: August 19, 2020

SUBJECT: Ammunition (Annual Contract); RFB No. 20-0062

FROM: Patti Postorino, Purchasing Division

Please route for appropriate signatures the one (1) copy of each of the four attached contracts with Dana Safety Supply Inc (Greensboro, NC), Gulf States Distributors Inc (Montgomery, AL), Precision Delta Corporation (Ruleville, MS), and Smyrna Police Distributors Inc (Smyrna, GA) for the estimated annual contract value of \$191,077.40. These firms will provide ammunition and munitions of various types and quantities on an "as needed" basis to Columbus Consolidated Government (the City) to be utilized by the Public Safety Departments.

The term of this contract shall be for two (2) years with the option to renew for three (3) additional twelve-month periods. Contract renewal is contingent upon the mutual agreement of the City and the Contractor.

Funds are budgeted each fiscal year for this on-going expense:

Public Safety Departments: General Fund - Police, Marshal, Muscogee County Prison, and Sheriff - Operating Materials; 0101-400-2900-CTRN-6728, 0101-400-2200-STAF-6728, 0101-530-3000-MRSH-6728, 0101-420-1000-MCCI-6728, 0101-550-1000-SHRF-6728, 0101-550-2300-STRN-6728, 0101-550-2600-JAIL-6728, 0101-550-2100-SPTL-6728.

Council authorized this contract per Resolution No. 223-20, dated August 11, 2020 (copy is attached).

Signatories	Signatures Required (<i>No initials please</i>)	Date
Purchasing Division Manager Signature of Approval		8/19/20
City Attorney: Signature required on Contracts	Form Approved: Clerk, City Attorney	8/19/20
City Manager: Signature required on Contracts		8/25/2020
Clerk of Council: Signature Required on Contracts & Attest/Seal		8/26/2020
Buyer: Process / Distribute		08/28/2020

After all signatures have been applied, please contact Purchasing Division (ext - 3070) for distribution.

RESOLUTION

NO. 223-20

A RESOLUTION AUTHORIZING THE PURCHASE OF AMMUNITION AND MUNITIONS FROM DANA SAFETY SUPPLY, INC. (GREENSBORO, NC), GULF STATES DISTRIBUTORS, INC. (MONTGOMERY, AL), PRECISION DELTA CORPORATION (RULEVILLE, MS), AND SMYRNA POLICE DISTRIBUTORS, INC. (SMYRNA, GA), ON AN "AS NEEDED" BASIS, FOR THE ESTIMATED ANNUAL CONTRACT VALUE OF \$191,077.40.

WHEREAS, The various types of ammunition include: duty ammunition, practice ammunition, and shotgun ammunition. The munitions supplies include: smoke canisters, tactical grenades, stinger rubber ball grenades, etc. The ammunition and munitions will be used by Columbus Public Safety Departments (Police, Marshal, Muscogee County Prison and Sheriff) and will be purchased on an "as needed" basis; and,

WHEREAS, the initial contract period shall be for two years, with the option to renew for three additional twelve-month periods. Contract renewals will be contingent upon the mutual agreement of the City and the Contractor.

NOW, THEREFORE, THE COUNCIL OF COLUMBUS, GEORGIA, HEREBY RESOLVES AS FOLLOWS:

That the City Manager is hereby authorized to purchase ammunition and munitions from Dana Safety Supply, Inc. (Greensboro, NC), Gulf States Distributors, Inc. (Montgomery, AL), Precision Delta Corporation (Ruleville, MS) and Smyrna Police Distributors, Inc. (Smyrna, GA) on an "as needed" basis, for the estimated annual contract value of \$191,077.40. Funds are budgeted each fiscal year for this on-going expense: General Fund - Police, Marshal, Muscogee County Prison, and Sheriff - Operating Materials; 0101-400-2900-CTRN-6728, 0101-400-2200-STAF-6728, 0101-530-3000-MRSH-6728, 0101-420-1000-MCCI-6728, 0101-550-1000-SHRF-6728; 0101-550-2300-STRN-6728; 0101-550-2600-JAIL-6728, 0101-550-2100-SPTL-6728.

Introduced at a regular meeting of the Council of Columbus, Georgia, held the 11th day of August 2020 and adopted at said meeting by the affirmative vote of eight members of said Council.

Councilor Allen	voting <u>YES</u>
Councilor Barnes	voting <u>ABSENT FOR VOTE</u>
Councilor Crabb	voting <u>YES</u>
Councilor Davis	voting <u>YES</u>
Councilor Garrett	voting <u>YES</u>

Councilor House	voting	<u> </u> YES <u> </u>
Councilor Huff	voting	<u> </u> YES <u> </u>
Councilor Thomas	voting	<u> </u> YES <u> </u>
Councilor Thompson	voting	<u> </u> YES <u> </u>
Councilor Woodson	voting	<u> </u> ABSENT <u> </u>



Sandra T. Davis
Clerk of Council

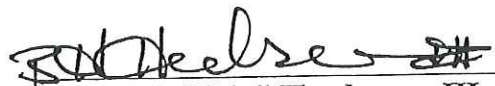

B. H. "Skip" Henderson, III
Mayor

CONTRACT

THIS CONTRACT, executed this 25th day of August 2020, by and between the **Consolidated Government of Columbus, Georgia**, hereinafter called the "City", and **Precision Delta Corporation (Ruleville, MS)**, hereinafter called the "Contractor".

WITNESSETH:

That in consideration of the mutual covenants, obligations, and terms set-forth in the attached proposal and specifications, the parties hereby agree as follows:

1. That the Contractor met all proposal requirements and was evaluated most responsive for providing **Ammunition for Public Safety Departments (Annual Contract)**, per **RFB No. 20-0062**, and was awarded the Contract by Columbus City Council on Tuesday, August 11, 2020, Resolution No. 223-20, for the contract term of two years, beginning October 1, 2020 through September 30, 2022, for furnishing the same in accordance with the specifications prepared by the City and the proposal of the Contractor.

2. The Contractor will, at its own cost and expense, furnish all tools, materials and labor required to be furnished, provide all related services required, and meet all other requirements or conditions imposed, all strictly in accordance with the City's Business Requirements, the City's Request for Bids, dated May 20, 2020 (and all addenda thereto), the Contractor's bid dated June 17, 2020 and the awarded items which are attached hereto as exhibits "A", "B" and "C" respectively, and which are by reference made a part hereof to the same extent as if fully set out herein.

3. On the faithful performance of this Contract by the Contractor, the City will pay the Contractor in accordance with the terms and on the conditions stated in this Contract and the exhibits attached to and by reference made a part hereof.

FORM 3

CONTRACT SIGNATURE PAGE

AMMUNITION FOR PUBLIC SAFETY DEPARTMENTS (ANNUAL CONTRACT) RFB No. 20-0062

THE UNDERSIGNED HEREBY DECLARES THAT HE HAS/THEY HAVE CAREFULLY EXAMINED THE SPECIFICATIONS HEREIN REFERRED TO AND WILL PROVIDE ALL EQUIPMENT, TERMS AND SERVICES TO THE CONSOLIDATED GOVERNMENT OF COLUMBUS, GEORGIA.

Witness signatures: Joseph Truman II, Judy R. Saamun. Includes text: 'Witness as to the signing of the contract' and '(Corporate seal, if applicable)'.

Signature of Patricia Lott dated 6-15-20. Includes text: 'Signature of Authorized Representative Date', 'Patricia Lott Vice President', 'Print Name and Title of Signatory', and 'Precision Delta Corporation', 'Company Name'.

Company Ordering Address

Company Ordering Address: Precision Delta Corporation, PO Box 128, Ruleville MS 38771. Contact: Patricia Lott. Email: precdelta@tecinfo.net. Telephone: 662 756 2810. Fax: 662 756 2590.

Company Payment Address

Company Payment Address: Precision Delta Corporation, PO Box 128, Ruleville MS 38771. Contact: Patricia Lott, Ginger Stillions. Email: Ginger@PrecisionDelta.com. Telephone: 662 756 2810. Fax: 662 756 2590.

CONSOLIDATED GOVERNMENT OF COLUMBUS, GEORGIA

Accepted this 25th day of August 2020. Signature of Isaiah Hugley, City Manager.

APPROVED AS TO LEGAL FORM: Signature of Clifton C. Fay, City Attorney.

ATTEST: Signature of Sandra T. Davis, Clerk of Council.

EXECUTION AUTHORIZED. By Resolution No. 223-20. Signature of Clerk of Council.

<u>VENDOR / ITEMS</u>	<u>EST QTY</u>	<u>UNIT PRICE</u>	<u>TOTAL COST</u>
Precision Delta Corporation (Ruleville, MS)			
38 SPL - Precision - 148gr - Hollow Base Wadcutter	25,000	0.273	\$6,825.00
9mm - Winchester - 147gr - Sub sonic FMJ	20,000	0.205	\$4,100.00
VENDOR TOTAL ESTIMATED ANNUAL CONTRACT VALUE			\$ 10,925.00

EXHIBIT A

Columbus Consolidated Government

Ammunition for Public Safety Departments (Annual Contract)

RFB No. 20-0062

Business Requirements

VC 06696

Form **W-9**
(Rev. October 2019)
Department of the Treasury
Internal Revenue Service

**Request for Taxpayer
Identification Number and Certification**

Give Form to the
requester. Do not
send to the IRS.

Go to www.irs.gov/FormW9 for instructions and the latest information.

1 Name (as shown on your income tax return). Name is required on this line; do not leave this line blank.
Precision Delta Corporation

2 Business name/disregarded entity name, if different from above

3 Check appropriate box for federal tax classification of the person whose name is entered on line 1. Check only one of the following seven boxes.

Individual/sole proprietor or single-member LLC

C Corporation

S Corporation

Partnership

Trust/estate

Limited liability company. Enter the tax classification (C=C corporation, S=S corporation, P=Partnership) ▶ _____

Note: Check the appropriate box in the line above for the tax classification of the single-member owner. Do not check LLC if the LLC is classified as a single-member LLC that is disregarded from the owner unless the owner of the LLC is another LLC that is not disregarded from the owner for U.S. federal tax purposes. Otherwise, a single-member LLC that is disregarded from the owner should check the appropriate box for the tax classification of its owner.

Other (see instructions) ▶ _____

4 Exemptions (codes apply only to certain entities, not individuals; see instructions on page 3):

Exempt payee code (if any) _____

Exemption from FATCA reporting code (if any) _____

(Applies to accounts maintained outside the U.S.)

5 Address (number, street, and apt. or suite no.) (See instructions)
205 Hance St PO Box 128

6 City, state, and ZIP code
Rulerile MS 38771

7 List account number(s) here (optional)

Requester's name and address (optional)

Taxpayer Identification Number (TIN)

Enter your TIN in the appropriate box. The TIN provided must match the name given on line 1 to avoid backup withholding. For individuals, this is generally your social security number (SSN). However, for a resident alien, sole proprietor, or disregarded entity, see the instructions for Part I, later. For other entities, it is your employer identification number (EIN). If you do not have a number, see *How to get a TIN*, later.

Note: If the account is in more than one name, see the instructions for line 1. Also see *What Name and Number To Give the Requester* for guidelines on whose number to enter.

Social security number

or

Employer identification number

Certification

Under penalties of perjury, I certify that:

- The number shown on this form is my correct taxpayer identification number (or I am waiting for a number to be issued to me); and
- I am not subject to backup withholding because: (a) I am exempt from backup withholding, or (b) I have not been notified by the Internal Revenue Service (IRS) that I am subject to backup withholding as a result of a failure to report all interest or dividends, or (c) the IRS has notified me that I am no longer subject to backup withholding; and
- I am a U.S. citizen or other U.S. person (defined below); and
- The FATCA code(s) entered on this form (if any) indicating that I am exempt from FATCA reporting is correct.

Certification instructions. You must cross out item 2 above if you have been notified by the IRS that you are currently subject to backup withholding because you have failed to report all interest and dividends on your tax return. For real estate transactions, item 2 does not apply. For mortgage interest paid, acquisition or abandonment of secured property, cancellation of debt, contributions to an individual retirement arrangement (IRA), and generally, payments other than interest and dividends, you are not required to sign the certification, but you must provide your correct TIN. See the instructions for Part II, later.

Sign Here Signature of U.S. person ▶ **Gabriele Poff** Date ▶ **6-15-20**

General Instructions

Section references are to the Internal Revenue Code unless otherwise noted.

Future developments. For the latest information about developments related to Form W-9 and its instructions, such as legislation enacted after they were published, go to www.irs.gov/FormW9.

Purpose of Form

An individual or entity (Form W-9 requester) who is required to file an information return with the IRS must obtain your correct taxpayer identification number (TIN) which may be your social security number (SSN), individual taxpayer identification number (ITIN), adoption taxpayer identification number (ATIN), or employer identification number (EIN), to report on an information return the amount paid to you, or other amount reportable on an information return. Examples of information returns include, but are not limited to, the following.

- Form 1099-DIV (dividends, including those from stocks or mutual funds)
- Form 1099-MISC (various types of income, prizes, awards, or gross proceeds)
- Form 1099-B (stock or mutual fund sales and certain other transactions by brokers)
- Form 1099-S (proceeds from real estate transactions)
- Form 1099-K (merchant card and third party network transactions)
- Form 1098 (home mortgage interest), 1098-E (student loan interest), 1098-T (tuition)
- Form 1099-C (canceled debt)
- Form 1099-A (acquisition or abandonment of secured property)

Use Form W-9 only if you are a U.S. person (including a resident alien), to provide your correct TIN.

If you do not return Form W-9 to the requester with a TIN, you might be subject to backup withholding. See What is backup withholding, later.

08/18/2020

Search by TIN, Acct., or Name

Check for imported payees with non-matching TIN data and verify new payees

TIN Matching allows you to verify your Payee data against the IRS TIN Matching database to verify if you have the correct TIN.

Sovos can take care of your mismatched TINs & B-Notices

Sovos offers the ability to automatically mail the appropriate forms to your mismatched payees and request corrected information. The responses come directly to you, and the W-9/B-Notice solicitations are saved for your reference in File Manager. Depending on your subscription, additional fees may apply.

Print & Mail W-9 Solicitations

Print & Mail B-Notices

The W9 Solicitation button has been disabled as you have already sent your solicitations.

Mismatched Records

TIN	Name

Download

Individual TIN Lookup

Verify individual Payee Social Security and Employer ID numbers.

Name: Precision Delta Corporation TIN: [REDACTED] Verify Payee

TIN Status: PASS
OFAC Check: PASS
DMF Check: PASS

[Back to Home](#)

\$ 80

PRIVILEGE TAX LICENSE

002425



CITY OF RULEVILLE, STATE OF MISSISSIPPI
SUNFLOWER COUNTY

Received of Precision Delta Corporation
the sum of Eighty and no/100 Dollars
for Privilege License to carry on the business of Manufacturing

in the City of Ruleville, State of Mississippi for twelve months from date hereof.

Exp 09/30/2020
Clerk of the Board of Aldermen

Date at Ruleville, Mississippi, 10/14 20 19.
Brenda X. Willis
Tax Collector, City of Ruleville

AND
LICENSE
ISSUED

FOLD

EXHIBIT C

Columbus Consolidated Government

Ammunition for Public Safety Departments (Annual Contract)

RFB No. 20-0062

Precision Delta Corporation

Bid Submission

COLUMBUS CONSOLIDATED GOVERNMENT
Georgia's First Consolidated Government



FINANCE DEPARTMENT
PURCHASING DIVISION

100 TENTH STREET, P. O. Box 1340
COLUMBUS, GEORGIA 31902-1340
706-225-4087, Fax 706-225-3033
Bid Line 706-653-4536
www.columbusga.org

June 10, 2020

Addendum No. 1
Ammunition For Public Safety Departments
(Annual Contract)
RFB No. 20-0062

Submissions should include acknowledgement of receipt for all Addenda:

Authorized Initials: pl

Firm: Precision Delta Corporation

Vendors are informed that the above subject RFB is hereby modified, corrected, or supplemented as specified, described and set forth in this Addendum:

QUESTIONS / RESPONSES

Question: "Is Section III missing from new format? Section III Police.

Response: The Police Department wishes to receive bids on Section I: Ammunition and Section II: Less Lethal. There is no Section III.

Question: "Police Dept - Section 1, 5th Item 9mm 147gr Sub-Sonic Do they want JHP – USA9JHP2 or FMJ USA9mm1?"

Response: The specifications have been changed to add 9mm Winchester 147gr Sub-Sonic FMJ. See Section 1, Item 5., 9mm 147gr Sub-Sonic.

Question: "Marshal's Office - Section 1 9mm +40 S+W Do they want a "bonded" or "non-bonded"? Section 2 9mm +40 S+W Do they want JHP or FMJ training?"

Response: The specifications have been changed to add "Bonded". See Section 1, Item 3., 9mm and Item 4., .40 Caliber Federal.
The specifications have been changed to add JHP/Ball for practice ammunition. See Section 2, Item 1., 9mm and Item 2., .40 Caliber Federal,

Question: "Muscogee County Prison - 223 / 5.56mm What grain weight bullet do they want? 65gr or 55gr? Also, do they want a FMJ?"

Response: The specifications have been changed to add 65gr bullet FMJ, and is now Item 2 in the Section.

Question: "Sheriff's Office - 12 GA Rifle Slug Do they want a Reduced Recoil or Standard Load?"

Response: The specifications have been changed to add Reduced Recoil, and is now Item 5 in the Section.

Pricing Pages have been amended for all of the above items.
You must use the attached revised pricing pages.

Please use attached **"REVISED" PRICING PAGE** for each Public Safety Department. The "Pricing Page" for Police has been revised.

Andrea J. McCorvey
Purchasing Division Manager



“REVISED” PRICING PAGE
AMMUNITION FOR PUBLIC SAFETY DEPARTMENTS
 (Annual Contract) RFB NO. 20-0062

POLICE DEPARTMENT

VENDOR COMPANY NAME: *Precision Delta Corporation*

Section I: AMMUNITION

Item	Caliber or Gauge	Name Brand	Bullet Weight	Notes	Estimated Quantity	Unit Price (Per Round)	Total Price
1.	12 Gauge	Federal Winchester	00 Buck Shot	Reduced Recoil, 9 Pellet RA12005	25,000 RDS	\$.459	\$ 11,475.00
2.	223	Hornady Winchester	55gr	TAP RA223BSTAY	15,000 RDS	\$.715	\$ 10,725.00 2,625.00 per
3.	5.56	NATO Winchester	55 gr Ball	Reloaded New Q3131K	75,000 RDS	\$.315	\$ 23,625.00
4.	38SPL	* Precision * P14838F	148gr	Hollow Base Wadcutter	25,000 RDS	\$.273	\$ 6,825.00
5.	9MM	Winchester	147gr	Sub-Sonic FMJ USA9MM1	20,000 RDS	\$.205	\$ 4,100.00
6.	45ACP	Federal Winchester	230gr	Ball, Standard Velocity Q4170	10,000 RDS	\$.245	\$ 2,450.00
7.	308	Hornady Winchester	168gr	Match S308M	2,000 RDS	\$.941	\$ 1,882.00
8.	9mm	Reload Federal Winchester	124gr	FMJ USA9MM	20,000 RDS	\$.183	\$ 3,660.00
9.	223	Federal	55 BT	Gold Match Boat Tail, Hollow Point	3,000 RDS	\$ Not bid	\$ 0
10.	9mm	Hornady Winchester	135gr 147gr	Luger +P Flexlock Critical Duty RA981 Ranger ONE - Duty	10,000 RDS	\$.425	\$ 4,250.00
Total Section I							\$ 68,992.00

VENDOR COMPANY NAME:

Section II: LESS LETHAL

Item	Description	Estimated Quantity	Unit Price	Total Price
1.	CTS 37mm CS Liquid Barricade Smokeless	10 ea.	\$	\$
2.	CTS 37mm CS Powder Barricade Smokeless	10 ea.	\$	\$
3.	CTS 37mm OC Liquid Barricade Smokeless	10 ea.	\$	\$
4.	CTS Indoor OC Vapor Grenade	5 ea.	\$	\$
5.	CTS CS Baffled Canister Grenade, Pyro Low Flame Potential	5 ea.	\$	\$
6.	40mm Rotary – OC Muzzle Blast Rounds	200 ea.	\$	\$
7.	40mm Rotary – Long Range CS	100 ea.	\$	\$
8.	12 gauge Defense Technology Corp. Desc. Drag Stabilized Bean Bag	100 ea.	\$	\$
Total Section II				\$ 0
GRAND TOTAL Police Department (Sections I and II)				\$ 68,992.00

"REVISED" PRICING PAGE

AMMUNITION FOR PUBLIC SAFETY DEPARTMENTS
(ANNUAL CONTRACT) RFB NO. 20-0062

MARSHAL'S OFFICE

VENDOR COMPANY NAME: <i>Precision Delta Corporation</i>							
Section I: AMMUNITION							
Item	Caliber or Gauge	Name Brand	Bullet Weight	Notes	Estimated Quantity	Unit Price (Per Round)	Total Price
1.	12 Gauge	Remington LE <i>Winchester</i>	00 Buck, 8 Pellets	Reduced Recoil, PR12BK8-00 <i>RA12-0085</i>	1,500 RDS	\$.469	\$ 703.50
2.	223	Remington <i>Winchester</i>	55gr <i>RA-223B5T</i>	Remington Premier Accutip (PRA223RD)	4,000 RDS	\$.715	\$ 2,860.00
3.	9mm	Federal Tactical <i>Winchester</i>	147gr <i>RA9B1</i>	HST HP (P9HST2) New, Bonded	3,000 RDS	\$.425	\$ 1,275.00
4.	.40 Caliber	Federal Tactical <i>Winchester</i>	165gr <i>RA40TA</i>	Tactical HP (LE40T3), Bonded	1,000 RDS	\$.2907	\$ 290.70
Total Section I							\$ 5,129.20

Section II: PRACTICE AMMUNITION							
1.	9mm	Federal <i>Winchester</i>	147gr	JHP 850 FPR + P Ball <i>USA9MM1</i>	4,500 RDS	\$.205	\$ 922.50
2.	.40 Caliber	Federal <i>Winchester</i>	165gr	JHP/Ball <i>USA40SW</i>	500 RDS	\$.215	\$ 107.50
3.	.223 Caliber	Remington <i>Winchester</i>	55gr	Ball <i>USA223R1K</i> <i>L223R3BP1E</i>	8,000 RDS	\$.315	\$ 2,520.00
Total Section II							\$ 3,550.00

GRAND TOTAL Marshal's Office (Sections I and II)	\$ 8,679.20
---	--------------------

"REVISED" PRICING PAGE

AMMUNITION FOR PUBLIC SAFETY DEPARTMENTS
(ANNUAL CONTRACT) RFB NO. 20-0062

MUSCOGEE COUNTY PRISON (MCP)

VENDOR COMPANY NAME: <i>Precision Delta Corporation</i>							
PRACTICE AMMUNITION							
Item	Caliber or Gauge	Name Brand	Bullet Weight	Notes	Estimated Quantity	Unit Price (Per Round)	Total Price
1.	9 mill Automatic	Remington <i>Winchester</i>	115gr	FMJ <i>Q4172</i>	67,000 RDS	\$ <i>.1795</i>	\$ <i>12,026.50</i>
2.	223 / 556 Rifle	Remington <i>Winchester</i>	65gr <i>55gr</i>	FMJ <i>USA223R1K</i>	2,000 RDS	\$ <i>.315</i>	\$ <i>630.00</i>
3.	12 Gauge	Remington <i>Winchester</i>	00 Buckshot	Reduced Recoil, <i>RA-120085</i> 8 Pellet	2,000 RDS	\$ <i>.469</i>	\$ <i>938.00</i>
GRAND TOTAL (MCP)							\$ <i>13,594.50</i>

"REVISED" PRICING PAGE

AMMUNITION FOR PUBLIC SAFETY DEPARTMENTS
(ANNUAL CONTRACT) RFB NO. 20-0062

SHERIFF'S OFFICE

VENDOR COMPANY NAME: <i>Precision Delta Corporation</i>							
Section I: AMMUNITION							
Item	Caliber or Gauge	Name Brand	Bullet Weight	Notes	Estimated Quantity	Unit Price (Per Round)	Total Price
1.	.45 ACP	Hornady <i>Winchester</i>	230gr 220gr <i>+P</i>	FlexLock Critical Duty <i>RA45B</i>	13,000 RDS	\$ <i>.43</i>	\$ <i>5,590.00</i>
2.	9mm	Hornady <i>Winchester</i>	135gr <i>147gr</i>	Critical Duty <i>RA9B1</i>	13,000 RDS	\$ <i>.425</i>	\$ <i>5,525.00</i>
3.	.223 Cal	Hornady <i>Winchester</i>	55gr	FAP - Rifle <i>RA223B5TA</i>	4,000 RDS	\$ <i>.715</i>	\$ <i>2,860.00</i>
4.	12 Gauge	Remington <i>Winchester</i>	8 Pellet <i>RA120085</i>	00 Buckshot Reduced Recoil	1,000 RDS	\$ <i>.469</i>	\$ <i>469.00</i>
5.	12 Gauge	Remington <i>Winchester</i>	1 OZ <i>RA12RS15</i>	Rifle Slug Reduced Recoil	1,000 RDS	\$ <i>.52</i>	\$ <i>520.00</i>
6.	.45 ACP	Reload <i>Winchester</i>	230gr <i>New Ammo</i>	FMJ or Jacketed Hollow Point <i>Q4170</i>	100,000 RDS	\$ <i>.245</i>	\$ <i>24,500.00</i>
7.	9mm	Reload <i>Winchester</i>	115gr <i>New Ammo</i>	FMJ or Jacketed Hollow Point <i>Q4172</i>	100,000 RDS	\$ <i>.1795</i>	\$ <i>17,950.00</i>
8.	223 Cal	New <i>Winchester</i>	55gr	FMJ or Jacketed Hollow Point <i>USA223R1K</i>	32,000 RDS	\$ <i>.315</i>	\$ <i>10,080.00</i>
Total Section I						\$	<i>67,494.00</i>

“REVISED” PRICING PAGE

AMMUNITION FOR PUBLIC SAFETY DEPARTMENTS (ANNUAL CONTRACT) RFB NO. 20-0062

SHERIFF'S OFFICE

VENDOR COMPANY NAME:				
Section II: MUNITIONS				
<u>Item</u>	<u>Description</u>	<u>Estimated Quantity</u>	<u>Unit Price</u>	<u>Total Price</u>
<i>“All munitions that have a fuse with a pull ring must be equipped with a pull ring safety clip.”</i>				
1.	40mm Safe Smoke; 75 – 150 yards	50 ea.	\$	\$
2.	40mm Speed – Heat CS; 75 – 150 yards	70 ea.	\$	\$
3.	12 GA Diversionary Aerial Round	100 ea.	\$	\$
4.	12 GA Rubber Pellet Round	500 ea.	\$	\$
5.	12 GA Super Sock Bean Bag Round	150 ea.	\$	\$
6.	40mm Multiple Foam Baton, Smokeless 75-150 YD	20 ea.	\$	\$
Total Section II				\$ 0
Section III: HAND DEPLOYABLE MUNITIONS				
<i>“All munitions that have a fuse with a pull ring must be equipped with a pull ring safety clip.”</i>				
1.	Rubber Ball, w/ White Smoke	100 ea.	\$	\$
2.	Expulsion Grenade, Flameless	25 ea.	\$	\$
3.	Canister, Smoke	80 ea.	\$	\$
4.	Canister, Smoke, HC	50 ea.	\$	\$
5.	Canister, Smoke, Pocket	130 ea.	\$	\$
6.	Canister, CN	30 ea.	\$	\$
7.	Canister, OC	80 ea.	\$	\$
8.	Tactical Grenade, "Flash Bang"	25 ea.	\$	\$
9.	Tactical Grenade, "Flash Bang", Small	25 ea.	\$	\$
10.	Tactical Grenade, "Flash Bang", Training	25 ea.	\$	\$
11.	Tactical Grenade, "Flash Bang", Training, Small	25 ea.	\$	\$
12.	CS Grenades Handheld	30 ea.	\$	\$
13.	Stinger Rubber Ball Grenades	20 ea.	\$	\$
14.	Stinger Rubber Ball Grenades w/ OC	20 ea.	\$	\$
Total Section III				\$ 0
GRAND TOTAL Sheriff's Office (Sections I, II and III)				\$ 67,494.00

FORM 1

COMMUNICATION CONCERNING THIS SOLICITATION

THIS PAGE MUST BE SIGNED AND RETURNED WITH THE VENDOR'S BID/PROPOSAL. FAILURE TO INCLUDE THIS FORM WILL AUTOMATICALLY RENDER VENDOR'S RESPONSE NON-RESPONSIVE.

.....
ALL QUESTIONS OR CLARIFICATIONS CONCERNING THIS SOLICITATION SHALL BE SUBMITTED IN WRITING. THE CITY WILL NOT ORALLY OR TELEPHONICALLY ADDRESS ANY QUESTION OR CLARIFICATION REGARDING BID/PROPOSAL SPECIFICATIONS. IF A VENDOR VISITS OR CALLS THE PURCHASING DIVISION WITH SUCH QUESTIONS, HE OR SHE WILL BE INSTRUCTED TO SUBMIT THE QUESTIONS IN WRITING.

ALL CONTACT CONCERNING THIS SOLICITATION SHALL BE MADE THROUGH THE PURCHASING DIVISION. BIDDERS SHALL NOT CONTACT CITY EMPLOYEES, DEPARTMENT HEADS, USING AGENCIES, EVALUATION COMMITTEE MEMBERS, INCLUDING NON-CCG EMPLOYEES, CONTRACTED PERSONNEL ASSOCIATED WITH THIS PARTICULAR PROJECT (I.E. ARCHITECTS, ENGINEERS, CONSULTANTS), OR ELECTED OFFICIALS WITH QUESTIONS OR ANY OTHER CONCERNS ABOUT THE SOLICITATION. QUESTIONS, CLARIFICATIONS, OR CONCERNS SHALL BE SUBMITTED TO THE PURCHASING DIVISION IN WRITING. IF IT IS NECESSARY THAT A TECHNICAL QUESTION NEEDS ADDRESSING, THE PURCHASING DIVISION WILL FORWARD SUCH TO THE USING AGENCY, WHO WILL SUBMIT A WRITTEN RESPONSE.

THE PURCHASING DIVISION WILL FORWARD WRITTEN RESPONSES TO THE RESPECTIVE BIDDER. IF IT BECOMES NECESSARY TO REVISE ANY PART OF THIS SOLICITATION, A WRITTEN ADDENDUM WILL BE ISSUED TO ALL BIDDERS.

THE CITY IS NOT BOUND BY ANY ORAL REPRESENTATIONS, CLARIFICATIONS, OR CHANGES MADE TO THE WRITTEN SPECIFICATIONS BY CITY EMPLOYEES, UNLESS SUCH CLARIFICATION OR CHANGE IS PROVIDED TO THE BIDDERS IN A WRITTEN ADDENDUM FROM THE PURCHASING MANAGER.

BIDDERS ARE INSTRUCTED TO USE THE ENCLOSED "QUESTION/CLARIFICATION FORM" TO FAX OR EMAIL QUESTION. QUESTIONS AND REQUESTS FOR CLARIFICATION MUST BE SUBMITTED AT LEAST FIVE (5) BUSINESS DAYS BEFORE THE DUE DATE.

ANY REQUEST/CONCERN/PROTEST, AFTER A SOLICITATION HAS CLOSED AND PENDING AWARD, MUST ALSO BE SUBMITTED IN WRITING TO THE PURCHASING DIVISION.

.....
I agree to forward all communication about this solicitation, in writing, to the Purchasing Division. I understand that communication with other persons, other than the Purchasing Division, will render my Bid/Proposal response non-responsive and I will no longer be considered in the solicitation process.

Vendor Name: Precision Delta Corporation
Print Name of Authorized Agent: Patricia Lott
Signature of Authorized Agent: Patricia Lott

FORM 2

BID FORM

**AMMUNITION FOR PUBLIC SAFETY DEPARTMENTS
(ANNUAL CONTRACT)
RFB No. 20-0062**

IMPORTANT INFORMATION:

PLEASE SUBMIT ONE (1) ELECTRONIC BID RESPONSE VIA DEMANDSTAR.

By signing this Bid Form, the authorized representative understands the City reserves the right to request any omitted information, *with the exception of the "Communication Concerning This Solicitation" (Form 1), WHICH DOES NOT AFFECT THE SUBMITTED BID PRICE.* Bidders shall be notified, in writing, and shall have two (2) days, after notification to submit the omitted information. If the omitted information is not received within two (2) days, the Bidder shall be deemed non-responsive and the Bid Submission will be deemed "Incomplete". Use the following checklist to verify the items are included in sealed bid:

- Communication Concerning This Solicitation (Form 1) Bid Form (Form 2)
- Pricing Pages (pages 16-20) Contract Signature Page (Form 3) Production Literature
- Warranty & Shelf Life Info Sample Itemized Invoice Business License 2020 W-9 Rev 2018 (Form 4)

Initial below to acknowledge receipt of the following addenda (if any):

Addendum No. 1 pl Addendum No. 2 _____ Addendum No. 3 _____

The undersigned hereby declares that he has/they have carefully examined the specifications herein referred to and will provide all services and terms of the Columbus Consolidated Government.

*All shipping, delivery, and/or freight charges must be included in unit price. Columbus Consolidated Government will pay no additional shipping, delivery and/or freight charges or any other additional fees. Inability to make delivery within specified time will authorize the City to purchase from other sources.

Delivery will be made 30-90 day(s) after receipt of purchase order.

Precision Delta Corporation
Vendor Business Name

precdelta@tecinfo.net
Email Address

Patricia Lott
Authorized Signature

Patricia Lott
Print Name of Signatory

June 15, 2020
Date

Please circle and initial if Business is {Minority} or {Woman} Owned: _____

If certified as a DBE or WBE, list the certifying agency: _____

Not Minority, Woman or DBE owned (please initial) _____

FORM 3

CONTRACT SIGNATURE PAGE

**AMMUNITION FOR PUBLIC SAFETY DEPARTMENTS
(ANNUAL CONTRACT)
RFB No. 20-0062**

THE UNDERSIGNED HEREBY DECLARES THAT HE HAS/THEY HAVE CAREFULLY EXAMINED THE SPECIFICATIONS HEREIN REFERRED TO AND WILL PROVIDE ALL EQUIPMENT, TERMS AND SERVICES TO THE CONSOLIDATED GOVERNMENT OF COLUMBUS, GEORGIA.

Joseph Truman
Witness as to the signing of the contract
Judy R. Truman
Witness as to the signing of the contract
(Corporate seal, if applicable)

Patricia Lott 6-15-20
Signature of Authorized Representative Date
Patricia Lott Vicepresident
Print Name and Title of Signatory
Precision Delta Corporation
Company Name

Company Ordering Address

Precision Delta Corporation
PO Box 128 Ruleville Ms 38771
Contact Patricia Lott
Email precdelta@tecinfo.net
Telephone 662 756 2810
Fax 662 756 2590

Company Payment Address

Precision Delta Corporation
PO Box 128 Ruleville Ms 38771
Contact ~~Patricia Lott~~ Ginger Stillions
Email Ginger@PrecisionDelta.com
Telephone 662 756 2810
Fax 662 756 2590

CONSOLIDATED GOVERNMENT OF COLUMBUS, GEORGIA

Accepted this day of 20

APPROVED AS TO LEGAL FORM:

Isaiah Hugley, City Manager

Clifton C. Fay, City Attorney

ATTEST:

Sandra T. Davis, Clerk of Council



The Winchester Warranty

As manufacturer of the products provided, we warrant that these products comply with Winchester's exact specifications. They are free from defects in both material and workmanship. In the event that, within one year of product delivery date, Winchester establishes through investigation and testing that the products are defective, either in workmanship or material, Winchester will at its option, repair or replace the defective product free of charge, F.O.B. Winchester's East Alton Facility. These are buyer's exclusive remedies for claims under this Warranty. WINCHESTER MAKES NO OTHER WARRANTIES, EXPRESS OR IMPLIED, INCLUDING ANY WARRANTIES OF MERCHANTABILITY OR FITNESS FOR A PARTICULAR PURPOSE. If there are questions or should you need assistance, call our Product Service Department at (800) 356-2666 or (618) 258-2000.

**PRECISION DELTA
CORPORATION**

PO Box 128
Ruleville, MS 38771

Invoice

Date	Invoice #
6/16/2020	16946

Bill To
COLUMBUS CONSOLIDATED GOVT ATTN: ACCOUNTING DIVISION P.O. BOX 1340 COLUMBUS, GA 31902-1340

Ship To
COLUMBUS POLICE DEPT QUARTERMASTER 510 TENTH ST PUBLIC SAFETY BUILDING 1ST FLOOR COLUMBUS, GA 31901-2827



P.O. No.		Terms	Due Date	Account #	FET EXEMPTION	
SAMPLE PO		n/30	7/16/2020	GA-COLU-CONS-PD-01	7-19	
Item	Manufacture	Description		Qty	Rate	Amount
P14838F-Case	Precision Delta	38 Special 148 grain Hollow Base Wadcutter New Ammunition - Federal Primer 1000 rd/case **** SAMPLE INVOICE FOR RFB NO. 20-0062 ****		1	0.00	0.00
				Total	\$0.00	
				Payments/Credits	\$0.00	
				Balance Due	\$0.00	

Phone #	Fax #
662-756-2810	662-756-2590

COLUMBUS CONSOLIDATED GOVERNMENT ANNUAL CONTRACT ROUTING MEMORANDUM

DATE: August 19, 2020

SUBJECT: Ammunition (Annual Contract); RFB No. 20-0062

FROM: Patti Postorino, Purchasing Division

Please route for appropriate signatures the one (1) copy of each of the four attached contracts with Dana Safety Supply Inc (Greensboro, NC), Gulf States Distributors Inc (Montgomery, AL), Precision Delta Corporation (Ruleville, MS), and Smyrna Police Distributors Inc (Smyrna, GA) for the estimated annual contract value of \$191,077.40. These firms will provide ammunition and munitions of various types and quantities on an "as needed" basis to Columbus Consolidated Government (the City) to be utilized by the Public Safety Departments.

The term of this contract shall be for two (2) years with the option to renew for three (3) additional twelve-month periods. Contract renewal is contingent upon the mutual agreement of the City and the Contractor.

Funds are budgeted each fiscal year for this on-going expense:

Public Safety Departments: General Fund - Police, Marshal, Muscogee County Prison, and Sheriff - Operating Materials; 0101-400-2900-CTRN-6728, 0101-400-2200-STAF-6728, 0101-530-3000-MRSH-6728, 0101-420-1000-MCCI-6728, 0101-550-1000-SHRF-6728, 0101-550-2300-STRN-6728, 0101-550-2600-JAIL-6728, 0101-550-2100-SPTL-6728.

Council authorized this contract per Resolution No. 223-20, dated August 11, 2020 (copy is attached).

Signatories	Signatures Required (<i>No initials please</i>)	Date
Purchasing Division Manager Signature of Approval		8/19/20
City Attorney: Signature required on Contracts	Form Approved: C.C.F., City Attorney	8/19/20
City Manager: Signature required on Contracts		8/25/2020
Clerk of Council: Signature Required on Contracts & Attest/Seal		8/24/2020
Buyer: Process / Distribute		08/23/2020

After all signatures have been applied, please contact Purchasing Division (ext - 3070) for distribution.

RESOLUTION

NO. 223-20

A RESOLUTION AUTHORIZING THE PURCHASE OF AMMUNITION AND MUNITIONS FROM DANA SAFETY SUPPLY, INC. (GREENSBORO, NC), GULF STATES DISTRIBUTORS, INC. (MONTGOMERY, AL), PRECISION DELTA CORPORATION (RULEVILLE, MS), AND SMYRNA POLICE DISTRIBUTORS, INC. (SMYRNA, GA), ON AN "AS NEEDED" BASIS, FOR THE ESTIMATED ANNUAL CONTRACT VALUE OF \$191,077.40.

WHEREAS, The various types of ammunition include: duty ammunition, practice ammunition, and shotgun ammunition. The munitions supplies include: smoke canisters, tactical grenades, stinger rubber ball grenades, etc. The ammunition and munitions will be used by Columbus Public Safety Departments (Police, Marshal, Muscogee County Prison and Sheriff) and will be purchased on an "as needed" basis; and,

WHEREAS, the initial contract period shall be for two years, with the option to renew for three additional twelve-month periods. Contract renewals will be contingent upon the mutual agreement of the City and the Contractor.

NOW, THEREFORE, THE COUNCIL OF COLUMBUS, GEORGIA, HEREBY RESOLVES AS FOLLOWS:

That the City Manager is hereby authorized to purchase ammunition and munitions from Dana Safety Supply, Inc. (Greensboro, NC), Gulf States Distributors, Inc. (Montgomery, AL), Precision Delta Corporation (Ruleville, MS) and Smyrna Police Distributors, Inc. (Smyrna, GA) on an "as needed" basis, for the estimated annual contract value of \$191,077.40. Funds are budgeted each fiscal year for this on-going expense: General Fund - Police, Marshal, Muscogee County Prison, and Sheriff - Operating Materials; 0101-400-2900-CTRN-6728, 0101-400-2200-STAF-6728, 0101-530-3000-MRSH-6728, 0101-420-1000-MCCI-6728, 0101-550-1000-SHRF-6728; 0101-550-2300-STRN-6728; 0101-550-2600-JAIL-6728, 0101-550-2100-SPTL-6728.

Introduced at a regular meeting of the Council of Columbus, Georgia, held the 11th day of August 2020 and adopted at said meeting by the affirmative vote of eight members of said Council.

Councilor Allen	voting <u>YES</u>
Councilor Barnes	voting <u>ABSENT FOR VOTE</u>
Councilor Crabb	voting <u>YES</u>
Councilor Davis	voting <u>YES</u>
Councilor Garrett	voting <u>YES</u>

Councilor House voting YES
Councilor Huff voting YES
Councilor Thomas voting YES
Councilor Thompson voting YES
Councilor Woodson voting ABSENT



Sandra T. Davis
Clerk of Council



B. H. "Skip" Henderson, III
Mayor

CONTRACT

THIS CONTRACT, executed this 25th day of August 2020, by and between the **Consolidated Government of Columbus, Georgia**, hereinafter called the "City", and **Smyrna Police Distributors, Inc. (Smyrna, GA)**, hereinafter called the "Contractor".

WITNESSETH:

That in consideration of the mutual covenants, obligations, and terms set-forth in the attached proposal and specifications, the parties hereby agree as follows:

1. That the Contractor met all proposal requirements and was evaluated most responsive for providing **Ammunition for Public Safety Departments (Annual Contract)**, per **RFB No. 20-0062**, and was awarded the Contract by Columbus City Council on Tuesday, August 11, 2020, Resolution No. 223-20, for the contract term of two years, beginning October 1, 2020 through September 30, 2022, for furnishing the same in accordance with the specifications prepared by the City and the proposal of the Contractor.
2. The Contractor will, at its own cost and expense, furnish all tools, materials and labor required to be furnished, provide all related services required, and meet all other requirements or conditions imposed, all strictly in accordance with the City's Business Requirements, the City's Request for Bids, dated May 20, 2020 (and all addenda thereto), the Contractor's bid dated June 17, 2020 and the awarded items which are attached hereto as exhibits "A", "B" and "C" respectively, and which are by reference made a part hereof to the same extent as if fully set out herein.
3. On the faithful performance of this Contract by the Contractor, the City will pay the Contractor in accordance with the terms and on the conditions stated in this Contract and the exhibits attached to and by reference made a part hereof.

AMMUNITION FOR PUBLIC SAFETY DEPARTMENTS
(ANNUAL CONTRACT)
RFB No. 20-0062

THE UNDERSIGNED HEREBY DECLARES THAT HE HAS/THEY HAVE CAREFULLY EXAMINED THE SPECIFICATIONS HEREIN REFERRED TO AND WILL PROVIDE ALL EQUIPMENT, TERMS AND SERVICES TO THE CONSOLIDATED GOVERNMENT OF COLUMBUS, GEORGIA.

Witness as to the signing of the contract

[Signature] 06/16/2020
Signature of Authorized Representative Date

Witness as to the signing of the contract

Tra Hendricks, Sales
Print Name and Title of Signatory

(Corporate seal, if applicable)

Smyrna Police Distributors
Company Name

Company Ordering Address

2295 South Cobb Dr
Smyrna, GA 30080

Company Payment Address

630 B Windy Hill Rd
Smyrna, GA 30080

Contact Nick Wallace

Contact Vicki Boothe

Email nickwallace@spdist.com

Email Vicki.boothe@spdist.com

Telephone 7704341986

Telephone 7704347216

Fax _____

Fax _____

CONSOLIDATED GOVERNMENT OF COLUMBUS, GEORGIA

Accepted this 28th day of August 2020

APPROVED AS TO LEGAL FORM:

[Signature]
Isaiah Hugley, City Manager

[Signature]
Clifton C. Fay, City Attorney

EXECUTION AUTHORIZED

ATTEST:

[Signature]
Sandra T. Davis, Clerk of Council

By Resolution No. 223-20

[Signature]
Clerk of Council

<u>VENDOR / ITEMS</u>	<u>EST QTY</u>	<u>UNIT PRICE</u>	<u>TOTAL COST</u>
Smyrna Police Distributors, Inc. (Smyrna, GA)			
5.56 - NATO - 55gr - Ball - Reloaded	75,000	0.28	\$21,000.00
9mm - Hornady- 135gr - Luger +P Flexlock Critical Duty	10,000	0.3938	\$3,938.00
12 Gauge - Remington LE - 00 Buck, 8 Pellets - Reduced Recoil, PR12BK8-00	1,500	0.67	\$1,005.00
223 - Remington - 55gr - Remington Premier Accutip (PRA223RD)	4,000	0.65	\$2,600.00
.223 Caliber - Remington - 55gr - Ball L223R3BPLE	8,000	0.28	\$2,240.00
9 mill Automatic - Remington - 115gr - FMJ	67,000	0.18	\$12,060.00
223 / 556 Rifle - Remington - 65gr - FMJ	2,000	0.28	\$560.00
12 Gauge - Remington - 00 Buckshot - Reduced Recoil, 8 Pellet	2,000	0.67	\$1,340.00
.45 ACP - Hornady - 230gr +P - Flexlock Critical Duty	13,000	0.48	\$6,240.00
9mm - Hornady - 135gr - Critical Duty	13,000	0.3938	\$5,119.40
.223 - Hornady - 55gr - TAP, Rifle	4,000	0.5995	\$2,398.00
12 gauge - Remington - 8 Pellet - 00 Buckshot, Reduced Recoil	1,000	0.67	\$670.00
12 gauge - Remington 1 OZ - Rifle Slug, Reduced Recoil	1,000	0.64	\$640.00
.45 ACP - Reload - 230gr - FMJ or Jacketed Hollow Point	100,000	0.269	\$26,900.00
9mm - Reload - 115gr - FMJ or Jacketed Hollow Point	100,000	0.18	\$18,000.00
223 Cal - New - 55gr - FMJ or Jacketed Hollow Point	32,000	0.28	\$8,960.00
VENDOR TOTAL ESTIMATED ANNUAL CONTRACT VALUE			\$113,670.40

EXHIBIT A

Columbus Consolidated Government

Ammunition for Public Safety Departments (Annual Contract)

RFB No. 20-0062

Business Requirements

Request for Taxpayer Identification Number and Certification

Give Form to the
requester. Do not
send to the IRS.

▶ Go to www.irs.gov/FormW9 for instructions and the latest information.

Print or type.
See Specific Instructions on page 3.

1 Name (as shown on your income tax return). Name is required on this line; do not leave this line blank. Smyrna Police Distributors, Inc.	
2 Business name/disregarded entity name, if different from above	
3 Check appropriate box for federal tax classification of the person whose name is entered on line 1. Check only one of the following seven boxes. <input type="checkbox"/> Individual/sole proprietor or single-member LLC <input checked="" type="checkbox"/> C Corporation <input type="checkbox"/> S Corporation <input type="checkbox"/> Partnership <input type="checkbox"/> Trust/estate <input type="checkbox"/> Limited liability company. Enter the tax classification (C=C corporation, S=S corporation, P=Partnership) ▶ _____ <small>Note: Check the appropriate box in the line above for the tax classification of the single-member owner. Do not check LLC if the LLC is classified as a single-member LLC that is disregarded from the owner unless the owner of the LLC is another LLC that is not disregarded from the owner for U.S. federal tax purposes. Otherwise, a single-member LLC that is disregarded from the owner should check the appropriate box for the tax classification of its owner.</small> <input type="checkbox"/> Other (see instructions) ▶ _____	4 Exemptions (codes apply only to certain entities, not individuals; see instructions on page 3): Exempt payee code (if any) _____ Exemption from FATCA reporting code (if any) _____ <small>(Applies to accounts maintained outside the U.S.)</small>
5 Address (number, street, and apt. or suite no.) See instructions. 2295 South Cobb Drive	Requester's name and address (optional)
6 City, state, and ZIP code Smyrna, Georgia 30080	
7 List account number(s) here (optional)	

Part I Taxpayer Identification Number (TIN)

Enter your TIN in the appropriate box. The TIN provided must match the name given on line 1 to avoid backup withholding. For individuals, this is generally your social security number (SSN). However, for a resident alien, sole proprietor, or disregarded entity, see the instructions for Part I, later. For other entities, it is your employer identification number (EIN). If you do not have a number, see *How to get a TIN*, later.

Note: If the account is in more than one name, see the instructions for line 1. Also see *What Name and Number To Give the Requester* for guidelines on whose number to enter.

Social security number					
<table style="width: 100%; border-collapse: collapse;"> <tr> <td style="width: 25%; border: 1px solid black; height: 20px;"></td> <td style="width: 5%; border: 1px solid black; text-align: center;">-</td> <td style="width: 25%; border: 1px solid black; height: 20px;"></td> <td style="width: 5%; border: 1px solid black; text-align: center;">-</td> <td style="width: 40%; border: 1px solid black; height: 20px;"></td> </tr> </table>		-		-	
	-		-		
or					
Employer identification number					
<table style="width: 100%; border-collapse: collapse;"> <tr> <td style="width: 25%; border: 1px solid black; height: 20px;"></td> <td style="width: 25%; border: 1px solid black; height: 20px;"></td> <td style="width: 25%; border: 1px solid black; height: 20px;"></td> <td style="width: 25%; border: 1px solid black; height: 20px;"></td> </tr> </table>					

Part II Certification

Under penalties of perjury, I certify that:

1. The number shown on this form is my correct taxpayer identification number (or I am waiting for a number to be issued to me); and
2. I am not subject to backup withholding because: (a) I am exempt from backup withholding, or (b) I have not been notified by the Internal Revenue Service (IRS) that I am subject to backup withholding as a result of a failure to report all interest or dividends, or (c) the IRS has notified me that I am no longer subject to backup withholding; and
3. I am a U.S. citizen or other U.S. person (defined below); and
4. The FATCA code(s) entered on this form (if any) indicating that I am exempt from FATCA reporting is correct.

Certification Instructions. You must cross out item 2 above if you have been notified by the IRS that you are currently subject to backup withholding because you have failed to report all interest and dividends on your tax return. For real estate transactions, item 2 does not apply. For mortgage interest paid, acquisition or abandonment of secured property, cancellation of debt, contributions to an individual retirement arrangement (IRA), and generally, payments other than interest and dividends, you are not required to sign the certification, but you must provide your correct TIN. See the instructions for Part II, later.

Sign Here	Signature of U.S. person ▶	Date ▶ <u>01/01/2020</u>
------------------	----------------------------	--------------------------

General Instructions

Section references are to the Internal Revenue Code unless otherwise noted.

Future developments. For the latest information about developments related to Form W-9 and its instructions, such as legislation enacted after they were published, go to www.irs.gov/FormW9.

Purpose of Form

An individual or entity (Form W-9 requester) who is required to file an information return with the IRS must obtain your correct taxpayer identification number (TIN) which may be your social security number (SSN), individual taxpayer identification number (ITIN), adoption taxpayer identification number (ATIN), or employer identification number (EIN), to report on an information return the amount paid to you, or other amount reportable on an information return. Examples of information returns include, but are not limited to, the following.

- Form 1099-INT (interest earned or paid)

- Form 1099-DIV (dividends, including those from stocks or mutual funds)
 - Form 1099-MISC (various types of income, prizes, awards, or gross proceeds)
 - Form 1099-B (stock or mutual fund sales and certain other transactions by brokers)
 - Form 1099-S (proceeds from real estate transactions)
 - Form 1099-K (merchant card and third party network transactions)
 - Form 1098 (home mortgage interest), 1098-E (student loan interest), 1098-T (tuition)
 - Form 1099-C (canceled debt)
 - Form 1099-A (acquisition or abandonment of secured property)
- Use Form W-9 only if you are a U.S. person (including a resident alien), to provide your correct TIN.

If you do not return Form W-9 to the requester with a TIN, you might be subject to backup withholding. See What is backup withholding, later.

08/18/2020

Search by TIN, Acct., or Name

Check for imported payees with non-matching TIN data and verify new payees

TIN Matching allows you to verify your Payee data against the IRS TIN Matching database to verify if you have the correct information.

Sovos can take care of your mismatched TINs & B-Notices

Sovos offers the ability to automatically mail the appropriate forms to your mismatched payees and request corrected information. The responses come directly to you, and the W-9/B-Notice solicitations are saved for your reference in File Manager. Depending on your subscription, additional fees may apply.

Print & Mail W-9 Solicitations

Print & Mail B-Notices

The W9 Solicitation button has been disabled as you have already sent your solicitations.

Mismatched Records

TIN	Name

[Download All](#)

Individual TIN Lookup

Verify individual Payee Social Security and Employer ID numbers.

Name: TIN:

[Verify Payee](#)

TIN Status: PASS

OFAC Check: PASS

DMF Check: PASS

[Back to Home](#)

POST IN A
CONSPICUOUS
PLACE

SMYRNA GEORGIA
Occupation Tax Certificate
THIS LICENSE EXPIRES : 12/31/2020

Business ID
4719

SMYRNA POLICE DISTRIBUTORS INC
SMYRNA POLICE DISTRIBUTORS INC
2295 S COBB DR SE
SMYRNA, GA 30080



Category: GENERAL 1
Type: RETAIL TRADE - OTHER
Note: 2295 S COBB DR SE
Issue Date:
Business ID: 4719

PAID

This License is NOT Transferable

SMYRNA GEORGIA
Occupation Tax Certificate
THIS LICENSE EXPIRES : 12/31/2020

Business ID
4719

SMYRNA POLICE DISTRIBUTORS INC
SMYRNA POLICE DISTRIBUTORS INC
2295 S COBB DR SE
SMYRNA, GA 30080



Category: GENERAL 1
Type: RETAIL TRADE - OTHER
Note: 2295 S COBB DR SE
Issue Date:

Business ID: 4719

Total Received.... \$4,045.00

EXHIBIT C

Columbus Consolidated Government

Ammunition for Public Safety Departments (Annual Contract)

RFB No. 20-0062

Smyrna Police Distributors, Inc.

Bid Submission

COLUMBUS CONSOLIDATED GOVERNMENT
Georgia's First Consolidated Government



FINANCE DEPARTMENT
PURCHASING DIVISION

100 TENTH STREET, P. O. BOX 1340
COLUMBUS, GEORGIA 31902-1340
706-225-4087, Fax 706-225-3033
Bid Line 706-653-4536
www.columbusga.org

June 10, 2020

Addendum No. 1
Ammunition For Public Safety Departments
(Annual Contract)
RFB No. 20-0062

Submissions should include acknowledgement of receipt for all Addenda:	
Authorized Initials: <u>GD</u>	Firm: <u>Smyrna Police Dist.</u>

Vendors are informed that the above subject RFB is hereby modified, corrected, or supplemented as specified, described and set forth in this Addendum:

QUESTIONS / RESPONSES

Question: "Is Section III missing from new format? Section III Police.

Response: The Police Department wishes to receive bids on Section I: Ammunition and Section II: Less Lethal. There is no Section III.

Question: "Police Dept - Section 1, 5th Item 9mm 147gr Sub-Sonic Do they want JHP - USA9JHP2 or FMJ USA9mm1?"

Response: The specifications have been changed to add 9mm Winchester 147gr Sub-Sonic FMJ. See Section 1, Item 5., 9mm 147gr Sub-Sonic.

Question: "Marshal's Office - Section 1 9mm +40 S+W Do they want a "bonded" or "non-bonded"? Section 2 9mm +40 S+W Do they want JHP or FMJ training?"

Response: The specifications have been changed to add "Bonded". See Section 1, Item 3., 9mm and Item 4., .40 Caliber Federal. The specifications have been changed to add JHP/Ball for practice ammunition. See Section 2, Item 1., 9mm and Item 2., .40 Caliber Federal,

Question: "Muscogee County Prison - 223 / 5.56mm What grain weight bullet do they want? 65gr or 55gr? Also, do they want a FMJ?"

Response: The specifications have been changed to add 65gr bullet FMJ, and is now Item 2 in the Section.

Question: "Sheriff's Office - 12 GA Rifle Slug Do they want a Reduced Recoil or Standard Load?"

Response: The specifications have been changed to add Reduced Recoil, and is now Item 5 in the Section.

Pricing Pages have been amended for all of the above items.
You must use the attached revised pricing pages.

Please use attached **"REVISED" PRICING PAGE** for each Public Safety Department. The "Pricing Page" for Police has been revised.

Andrea J. McCorvey
Purchasing Division Manager

FORM 1

COMMUNICATION CONCERNING THIS SOLICITATION

THIS PAGE MUST BE SIGNED AND RETURNED WITH THE VENDOR'S BID/PROPOSAL. FAILURE TO INCLUDE THIS FORM WILL AUTOMATICALLY RENDER VENDOR'S RESPONSE NON-RESPONSIVE.

.....
ALL QUESTIONS OR CLARIFICATIONS CONCERNING THIS SOLICITATION SHALL BE SUBMITTED IN WRITING. THE CITY WILL NOT ORALLY OR TELEPHONICALLY ADDRESS ANY QUESTION OR CLARIFICATION REGARDING BID/PROPOSAL SPECIFICATIONS. IF A VENDOR VISITS OR CALLS THE PURCHASING DIVISION WITH SUCH QUESTIONS, HE OR SHE WILL BE INSTRUCTED TO SUBMIT THE QUESTIONS IN WRITING.

ALL CONTACT CONCERNING THIS SOLICITATION SHALL BE MADE THROUGH THE PURCHASING DIVISION. BIDDERS SHALL NOT CONTACT CITY EMPLOYEES, DEPARTMENT HEADS, USING AGENCIES, EVALUATION COMMITTEE MEMBERS, INCLUDING NON-CCG EMPLOYEES, CONTRACTED PERSONNEL ASSOCIATED WITH THIS PARTICULAR PROJECT (I.E. ARCHITECTS, ENGINEERS, CONSULTANTS), OR ELECTED OFFICIALS WITH QUESTIONS OR ANY OTHER CONCERNS ABOUT THE SOLICITATION. QUESTIONS, CLARIFICATIONS, OR CONCERNS SHALL BE SUBMITTED TO THE PURCHASING DIVISION IN WRITING. IF IT IS NECESSARY THAT A TECHNICAL QUESTION NEEDS ADDRESSING, THE PURCHASING DIVISION WILL FORWARD SUCH TO THE USING AGENCY, WHO WILL SUBMIT A WRITTEN RESPONSE.

THE PURCHASING DIVISION WILL FORWARD WRITTEN RESPONSES TO THE RESPECTIVE BIDDER. IF IT BECOMES NECESSARY TO REVISE ANY PART OF THIS SOLICITATION, A WRITTEN ADDENDUM WILL BE ISSUED TO ALL BIDDERS.

THE CITY IS NOT BOUND BY ANY ORAL REPRESENTATIONS, CLARIFICATIONS, OR CHANGES MADE TO THE WRITTEN SPECIFICATIONS BY CITY EMPLOYEES, UNLESS SUCH CLARIFICATION OR CHANGE IS PROVIDED TO THE BIDDERS IN A WRITTEN ADDENDUM FROM THE PURCHASING MANAGER.

BIDDERS ARE INSTRUCTED TO USE THE ENCLOSED "QUESTION/CLARIFICATION FORM" TO FAX OR EMAIL QUESTION. QUESTIONS AND REQUESTS FOR CLARIFICATION MUST BE SUBMITTED AT LEAST FIVE (5) BUSINESS DAYS BEFORE THE DUE DATE.

ANY REQUEST/CONCERN/PROTEST, AFTER A SOLICITATION HAS CLOSED AND PENDING AWARD, MUST ALSO BE SUBMITTED IN WRITING TO THE PURCHASING DIVISION.

I agree to forward all communication about this solicitation, in writing, to the Purchasing Division. I understand that communication with other persons, other than the Purchasing Division, will render my Bid/Proposal response non-responsive and I will no longer be considered in the solicitation process.

Vendor Name: Smyrna Police Distributors
Print Name of Authorized Agent: Tray Hendricks
Signature of Authorized Agent: [Signature]

AMMUNITION FOR PUBLIC SAFETY DEPARTMENTS
(ANNUAL CONTRACT)
RFB No. 20-0062

IMPORTANT INFORMATION:
PLEASE SUBMIT ONE (1) ELECTRONIC BID RESPONSE VIA DEMANDSTAR.

By signing this Bid Form, the authorized representative understands the City reserves the right to request any omitted information, with the exception of the "Communication Concerning This Solicitation" (Form 1), WHICH DOES NOT AFFECT THE SUBMITTED BID PRICE. Bidders shall be notified, in writing, and shall have two (2) days, after notification to submit the omitted information. If the omitted information is not received within two (2) days, the Bidder shall be deemed non-responsive and the Bid Submission will be deemed "Incomplete". Use the following checklist to verify the items are included in sealed bid:

Communication Concerning This Solicitation (Form 1) Bid Form (Form 2)
 Pricing Pages (pages 16-20) Contract Signature Page (Form 3) Production Literature
 Warranty & Shelf Life Info Sample Itemized Invoice Business License 2020 W-9 Rev 2018 (Form 4)

Initial below to acknowledge receipt of the following addenda (if any):

Addendum No. 1 Addendum No. 2 _____ Addendum No. 3 _____

The undersigned hereby declares that he has/they have carefully examined the specifications herein referred to and will provide all services and terms of the Columbus Consolidated Government.

*All shipping, delivery, and/or freight charges must be included in unit price. Columbus Consolidated Government will pay no additional shipping, delivery and/or freight charges or any other additional fees. Inability to make delivery within specified time will authorize the City to purchase from other sources.

Delivery will be made 60-90 day(s) after receipt of purchase order.

Smyrna Police Distributors nickwallace@spdlist.com
Vendor Business Name Email Address

[Signature] Troy Hendricks 06/16/2020
Authorized Signature Print Name of Signatory Date

Please circle and initial if Business is {Minority} or {Woman} Owned: _____

If certified as a DBE or WBE, list the certifying agency: _____

Not Minority, Woman or DBE owned (please initial) 1

“REVISED” PRICING PAGE
AMMUNITION FOR PUBLIC SAFETY DEPARTMENTS
 (Annual Contract) RFB NO. 20-0062

POLICE DEPARTMENT

VENDOR COMPANY NAME: *Smyrna Police Distributors*

Section I: AMMUNITION

Item	Caliber or Gauge	Name Brand	Bullet Weight	Notes	Estimated Quantity	Unit Price (Per Round)	Total Price
1.	12 Gauge	Federal	00 Buck Shot	Reduced Recoil, 9 Pellet	25,000 RDS	\$ 5.795	\$ No BID.
2.	223	Hornady	55gr	TAP 83276	15,000 RDS	\$ 0.5995	\$ 8992 ⁵⁰
3.	5.56	NATO	55 gr Ball	Reloaded Rem 23391	75,000 RDS	\$ 0.28	\$ 21,000 ⁰⁰
4.	38SPL	Precision	148gr	Hollow Base Wadcutter	25,000 RDS	\$ —	\$ NO BID
5.	9MM	Winchester	147gr	Sub-Sonic FMJ	20,000 RDS	\$ —	\$ NO BID.
6.	45ACP	Federal Remington	230gr	Ball, Standard Velocity 23726	10,000 RDS	\$ 0.295	\$ 2950 ⁰⁰
7.	308	Hornady	168gr	Match 80725	2,000 RDS	\$ 1.10	\$ 2200 ⁰⁰
8.	9mm	Reload Federal.	124gr	FMJ Rem 23718	20,000 RDS	\$ 0.18	\$ 3600 ⁰⁰
9.	223	Federal	55 BT	Gold Match Boat Tail, Hollow Point	3,000 RDS	\$ —	\$ No BID
10.	9mm	Hornady 40225	135gr	Luger +P Flexlock Critical Duty	10,000 RDS	\$ 0.3938	\$ 3938 ⁰⁰
Total Section I							\$ 42,680 ⁵⁰

VENDOR COMPANY NAME: *Smyrna Police Distributors*

Section II: LESS LETHAL

Item	Description	Estimated Quantity	Unit Price	Total Price
1.	CTS 37mm CS Liquid Barricade Smokeless	10 ea.	\$ No BID	\$ No BID
2.	CTS 37mm CS Powder Barricade Smokeless	10 ea.	\$	\$
3.	CTS 37mm OC Liquid Barricade Smokeless	10 ea.	\$	\$
4.	CTS Indoor OC Vapor Grenade	5 ea.	\$	\$
5.	CTS CS Baffled Canister Grenade, Pyro Low Flame Potential	5 ea.	\$	\$
6.	40mm Rotary – OC Muzzle Blast Rounds	200 ea.	\$	\$
7.	40mm Rotary – Long Range CS	100 ea.	\$	\$
8.	12 gauge Defense Technology Corp. Desc. Drag Stabilized Bean Bag	100 ea.	\$	\$
Total Section II				\$ No BID.
GRAND TOTAL Police Department (Sections I and II)				\$ 42,680 ⁵⁰

"REVISED" PRICING PAGE

**AMMUNITION FOR PUBLIC SAFETY DEPARTMENTS
(ANNUAL CONTRACT) RFB NO. 20-0062**

MARSHAL'S OFFICE

VENDOR COMPANY NAME: <i>Smyrna Police Distributors.</i>							
Section I: AMMUNITION							
Item	Caliber or Gauge	Name Brand	Bullet Weight	Notes	Estimated Quantity	Unit Price (Per Round)	Total Price
1.	12 Gauge	Remington LE <i>20645</i>	00 Buck, 8 Pellets	Reduced Recoil, PR12BK8-00	1,500 RDS	\$.67	\$ <i>1005⁰⁰</i>
2.	223	Remington <i>29192.</i>	55gr	Remington Premier Accutip (PRA223RD)	4,000 RDS	\$.65	\$ <i>2600⁰⁰</i>
3.	9mm	Federal Tactical	147gr	HST HP (P9HST2) New, Bonded	3,000 RDS	\$ <i>No Bid</i>	\$ <i>---</i>
4.	.40 Caliber	Federal Tactical	165gr	Tactical HP (LE40T3), Bonded	1,000 RDS	\$ <i>No Bid</i>	\$ <i>---</i>
Total Section I							\$ <i>3605⁰⁰</i>

Section II: PRACTICE AMMUNITION							
1.	9mm	Federal	147gr	JHP 850 FPR + P Ball	4,500 RDS	\$ <i>No Bid</i>	\$ <i>---</i>
2.	.40 Caliber	Federal	165gr	JHP/Ball	500 RDS	\$ <i>No Bid</i>	\$ <i>---</i>
3.	.223 Caliber	Remington <i>23891</i>	55gr	Ball L223R3BPPE	8,000 RDS	\$.28	\$ <i>2240⁰⁰</i>
Total Section II							\$ <i>2240⁰⁰</i>

GRAND TOTAL Marshal's Office (Sections I and II)	\$ <i>5845⁰⁰</i>
---	-----------------------------

"REVISED" PRICING PAGE

**AMMUNITION FOR PUBLIC SAFETY DEPARTMENTS
(ANNUAL CONTRACT) RFB NO. 20-0062**

MUSCOGEE COUNTY PRISON (MCP)

VENDOR COMPANY NAME: <i>Smyrna Police Distributors</i>							
PRACTICE AMMUNITION							
<u>Item</u>	<u>Caliber or Gauge</u>	<u>Name Brand</u>	<u>Bullet Weight</u>	<u>Notes</u>	<u>Estimated Quantity</u>	<u>Unit Price (Per Round)</u>	<u>Total Price</u>
1.	9 mill Automatic	Remington <i>23718</i>	115gr	FMJ	67,000 RDS	\$ <i>.18</i>	\$ <i>12060⁰⁰</i>
2.	223 / 556 Rifle	Remington <i>23891</i>	65gr <i>55gr.</i>	FMJ	2,000 RDS	\$ <i>.28</i>	\$ <i>560⁰⁰</i>
3.	12 Gauge	Remington <i>20645</i>	00 Buckshot	Reduced Recoil, 8 Pellet	2,000 RDS	\$ <i>.67</i>	\$ <i>1340⁰⁰</i>
GRAND TOTAL (MCP)							\$ <i>13960⁰⁰</i>

"REVISED" PRICING PAGE

**AMMUNITION FOR PUBLIC SAFETY DEPARTMENTS
(ANNUAL CONTRACT) RFB NO. 20-0062**

SHERIFF'S OFFICE

VENDOR COMPANY NAME: <i>Smyrna Police Distributors</i>							
Section I: AMMUNITION							
Item	Caliber or Gauge	Name Brand	Bullet Weight	Notes	Estimated Quantity	Unit Price (Per Round)	Total Price
1.	.45 ACP	Hornady <i>90225</i>	220gr +P	FlexLock Critical Duty	13,000 RDS	\$ <i>0.48</i>	\$ <i>6240⁰⁰</i>
2.	9mm	Hornady <i>90225</i>	135gr	Critical Duty	13,000 RDS	\$ <i>0.3938</i>	\$ <i>5119⁴⁰</i>
3.	.223 Cal	Hornady <i>83276</i>	55gr	TAP - Rifle <i>83276</i>	4,000 RDS	\$ <i>0.5995</i>	\$ <i>2398⁰⁰</i>
4.	12 Gauge	Remington <i>206H5</i>	8 Pellet	00 Buckshot Reduced Recoil	1,000 RDS	\$ <i>0.67</i>	\$ <i>670⁰⁰</i>
5.	12 Gauge	Remington <i>20279</i>	1 OZ	Rifle Slug Reduced Recoil	1,000 RDS	\$ <i>0.64</i>	\$ <i>640⁰⁰</i>
6.	.45 ACP <i>23653</i>	Reload <i>Remington</i>	230gr	FMJ or Jacketed Hollow Point	100,000 RDS	\$ <i>0.269</i>	\$ <i>26900⁰⁰</i>
7.	9mm <i>23718</i>	Reload <i>Remington</i>	115gr	FMJ or Jacketed Hollow Point	100,000 RDS	\$ <i>0.18</i>	\$ <i>18000⁰⁰</i>
8.	223 Cal <i>23891</i>	New <i>Remington</i>	55gr	FMJ or Jacketed Hollow Point	32,000 RDS	\$ <i>0.28</i>	\$ <i>8960⁰⁰</i>
Total Section I							\$ <i>68,927⁴⁰</i>

"REVISED" PRICING PAGE

**AMMUNITION FOR PUBLIC SAFETY DEPARTMENTS
(ANNUAL CONTRACT) RFB NO. 20-0062**

SHERIFF'S OFFICE

VENDOR COMPANY NAME:				
Section II: MUNITIONS				
<u>Item</u>	<u>Description</u>	<u>Estimated Quantity</u>	<u>Unit Price</u>	<u>Total Price</u>
<i>"All munitions that have a fuse with a pull ring must be equipped with a pull ring safety clip."</i>				
1.	40mm Safe Smoke; 75 – 150 yards	50 ea.	\$ No BIP	\$ No BIP
2.	40mm Speed – Heat CS; 75 – 150 yards	70 ea.	\$	\$
3.	12 GA Diversionsary Aerial Round	100 ea.	\$	\$
4.	12 GA Rubber Pellet Round	500 ea.	\$	\$
5.	12 GA Super Sock Bean Bag Round	150 ea.	\$	\$
6.	40mm Multiple Foam Baton, Smokeless 75-150 YD	20 ea.	\$	\$
Total Section II				\$ No BIP
Section III: HAND DEPLOYABLE MUNITIONS				
<i>"All munitions that have a fuse with a pull ring must be equipped with a pull ring safety clip."</i>				
1.	Rubber Ball, w/ White Smoke	100 ea.	\$ No BIP	\$ No BIP
2.	Expulsion Grenade, Flameless	25 ea.	\$	\$
3.	Canister, Smoke	80 ea.	\$	\$
4.	Canister, Smoke, HC	50 ea.	\$	\$
5.	Canister, Smoke, Pocket	130 ea.	\$	\$
6.	Canister, CN	30 ea.	\$	\$
7.	Canister, OC	80 ea.	\$	\$
8.	Tactical Grenade, "Flash Bang"	25 ea.	\$	\$
9.	Tactical Grenade, "Flash Bang", Small	25 ea.	\$	\$
10.	Tactical Grenade, "Flash Bang", Training	25 ea.	\$	\$
11.	Tactical Grenade, "Flash Bang", Training, Small	25 ea.	\$	\$
12.	CS Grenades Handheld	30 ea.	\$	\$
13.	Stinger Rubber Ball Grenades	20 ea.	\$	\$
14.	Stinger Rubber Ball Grenades w/ OC	20 ea.	\$	\$
Total Section III				\$ No BIP
GRAND TOTAL Sheriff's Office (Sections I, II and III)				\$ 68,974 ⁴⁰

FORM 3

CONTRACT SIGNATURE PAGE

**AMMUNITION FOR PUBLIC SAFETY DEPARTMENTS
(ANNUAL CONTRACT)
RFB No. 20-0062**

THE UNDERSIGNED HEREBY DECLARES THAT HE HAS/THEY HAVE CAREFULLY EXAMINED THE SPECIFICATIONS HEREIN REFERRED TO AND WILL PROVIDE ALL EQUIPMENT, TERMS AND SERVICES TO THE CONSOLIDATED GOVERNMENT OF COLUMBUS, GEORGIA.

Witness as to the signing of the contract

[Signature] 06/16/2020
Signature of Authorized Representative Date

Witness as to the signing of the contract

Traffordicks, Sales
Print Name and Title of Signatory

(Corporate seal, if applicable)

Smyrna Police Distributors
Company Name

Company Ordering Address

2295 South Cobb Dr
Smyrna, GA 30080

Company Payment Address

630-B Windy Hill Rd
Smyrna, GA 30080

Contact Nick Wallace

Contact Vicki Boothe

Email NickWallace@spdist.com

Email VickiBoothe@spdist.com

Telephone 7704341986

Telephone 7704347216

Fax _____

Fax _____

CONSOLIDATED GOVERNMENT OF COLUMBUS, GEORGIA

Accepted this ___ day of _____ 20__

APPROVED AS TO LEGAL FORM:

Isaiah Hugley, City Manager

Clifton C. Fay, City Attorney

ATTEST:

Sandra T. Davis, Clerk of Council

Remington Ammunition Warranty Information –

Limited Lifetime Warranty –

When there is a concern regarding our ammunition, we request that you please call us at 1-800-243-9700 with your Name, Address, type of ammunition, type of failure, and the firearms used.

Once we receive this information, we will forward it to our ammunition plant so that we can send you a prepaid shipping label, and all appropriate packaging materials to send the ammunition back for testing.

We will contact you once our evaluation and testing have been completed to determine the best course of action in order to resolve this issue for you.

Ammunition should be stored in the factory carton or package. The labeling and identification on the original package helps to ensure proper future use. Ammunition should be stored in a locked closet or cabinet in a cool, dry area away from children, and away from firearms. Obviously, poor storage conditions, such as a humid or corrosive atmosphere, could cause product damage immediately.

The shelf life of properly stored ammunition is approximately 10 years.

If ammunition is exposed to fire or if ammunition is older than shelf life, contact your local authorities for assistance with proper disposal.

Hornady Ammunition Warranty –

All Hornady ammunition is warranted against material and workmanship defects. If the ammunition is found to be defective due to material or workmanship, Hornady will replace the defective ammunition at no charge to the customer.

All ammunition warranty claims are handled on a case-by-case basis. In order to initiate a claim, please contact our Customer Service Technicians at 800-338-3220.

All ammunition warranty claims must have a Return Authorization (RA) number assigned before acceptance at our facility for further examination. Please DO NOT send ammunition without obtaining an RA number from our Customer Service staff.

NOTE: Improper storage and handling of ammunition may result in damage to the product. The appearance of exposure, corrosion or any other evidence of damage that occurred after the product was sold will void any warranties.

To return a product, send with transportation prepaid, to:

Hornady Manufacturing Company
3625 West Old Potash Highway
Grand Island, NE 68803

Prices and/or specifications are subject to change without notice.

Invoice # 54671
 Smyrna Police Distributors

SAMPLE INVOICE

Ship To: Muscogee County Sheriff's Office
 Training Division
 7149 Manor Road
 Columbus, Georgia 31902-1340

Smyrna Police Distributors
 630 Windy Hill Road
 Smyrna, GA 30080
 770-434-1986

Bill To: Columbus Consolidated Government
 Accounting Division
 P. O. Box 1340
 Columbus, Georgia 31902-1340

RFB No. 20-0062

Bill To: 229-430-5175
 Ship To: 229-430-5175

10/16/2019 4:49:37 PM
 Page 1

Mail #: 2294305175
 AR Acct #: SGRA01
 PO #: LETTERHEAD
 Order #: 43598

Fold Here Ship Date: 2/25/2019 FOB: Ship Via: Terms: Net 30 Days Packages: 0 Weight: 0 Clerk #: 32

Item #	Description 1	Style	Order Qty	Ship Qty	Price	Net Sale
999	REMINGTON SHOTGUN AMMO 12GA SLUG RIFLED HV	SPECIALORDER	5	5	12.95	64.75
999	REMINGTON RIFLE AMMO 270 130GR PSP	SPECIALORDER	2	2	18.50	37.00

Total 2	Units: 7	Subtotal	101.75
		Sales Tax	0.00
		Total Charge	101.75